

BOMANN®

Home Appliances 2017



CONTENT



| | |
|------------------|----|
| Coffee machines | 14 |
| Coffee grinder | 18 |
| Espresso machine | 17 |
| Kettle | 19 |
| Milk frother | 18 |
| Water kettle | 23 |



| | |
|----------------------|----|
| Automatic toasters | 25 |
| Crêpe maker | 28 |
| Egg boiler | 32 |
| Ice cream cone maker | 28 |
| Ice cube maker | 31 |
| Muffin maker | 29 |
| Multigrill | 30 |
| Pepper/salt mill | 32 |
| Sandwich toaster | 29 |
| Soft ice maker | 31 |
| Waffle maker | 27 |
| Yogurt maker | 31 |



| | |
|-----------------------|----|
| Automatic juicer | 49 |
| Bag sealer | 52 |
| Citrus fruit squeezer | 49 |
| Deep fat fryers | 52 |
| Fondue deep fat pan | 52 |
| Food dryer | 51 |
| Food processor | 45 |
| Food slicer | 32 |
| Hand blender | 33 |
| Hand blender sets | 34 |

| | |
|------------------|----|
| Hand mixer | 37 |
| Hand mixer sets | 39 |
| Kitchen scales | 51 |
| Kneading machine | 40 |
| Mincer | 46 |
| Multi express | 35 |
| Multi chopper | 35 |
| Smoothie maker | 48 |
| Universal mixer | 47 |

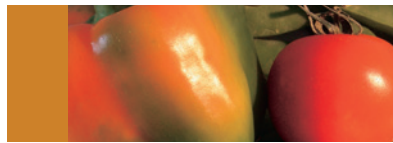

| | |
|--------------------------------|----|
| Bread maker | 55 |
| Barbecue standing grill | 60 |
| Barbecue table grill | 61 |
| Built-in microwaves with grill | 69 |
| Contact grill | 57 |
| Convection oven | 63 |
| Vertical doner multigrill | 62 |
| Gas grill | 62 |
| Hot dog maker | 56 |
| Hotplates | 71 |
| Induction hot plates | 72 |
| Microwaves | 66 |
| Mini kitchen | 65 |
| Mini oven | 63 |
| Multi oven | 64 |
| Multi pizza oven | 64 |
| Raclette grills | 59 |
| Rice boiler | 55 |
| Steam cooker | 56 |
| Party pans | 58 |



| | |
|----------------------|----|
| Steam irons | 74 |
| Mini-washing machine | 78 |
| Steam ironing unit | 77 |
| Textile cleaner | 73 |
| Fabric steamer | 78 |

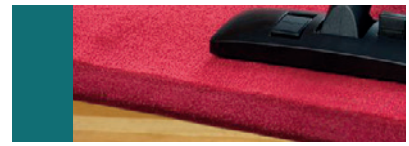

| | |
|------------------------------|----|
| Battery floor vacuum cleaner | 83 |
| Battery vacuum cleaner | 81 |
| Floor vacuum cleaner | 84 |
| Hand vacuum cleaner | 82 |
| High pressure cleaner | 80 |
| Steam cleaner | 79 |
| Steam mop | 80 |
| Wet and dry cleaner | 89 |
| Window cleaner | 81 |



| | |
|---------------------------|----|
| Bathroom scales | 89 |
| Foot massage equipment | 90 |
| Hair and beard trimmer | 91 |
| Hot air styler | 92 |
| Hair dryer | 93 |
| Nose and ear hair remover | 91 |



| | |
|------------------|-----|
| Accessoires | 100 |
| Air dehumidifier | 96 |
| Cool boxes | 98 |
| Ventilators | 95 |
| Wine cooler | 99 |
| Fan heater | 96 |



Universal mixer
UM 1569 CB => page 47

Kettle
WK 1566 CB => page 21



Automatic toaster
TA 1567 CB => page 25



Multi purpose mixer
MZ 1568 CB => page 37



Coffee machine
KA 1565 CB => page 16



Colour up



Hand blender
SM 384 CB => page 33



Multi chopper
MZ 449 CB => page 36



Hand mixer
HM 350 CB => page 38





Glass kitchen scale
KW 1515 CB => page 51

Smoothie maker
SM 386 CB => page 48



*your
life*



Kettle
WK 5011 CB => page 20





Coffee machine KA 1575 CB

- For 8–10 cups of coffee (approx. 1,25 litre)
- Anti-drip protection
- Swivel filter
- On/off switch with indicator light (blue illuminated)
- Water level indicator
- Heating plate with automatic switch-off
- 230 V, 50 Hz, 870 W max.



Kettle WK 1576 CB

- Max. capacity 1.7 litre
- Simple handling due to cable-free technology – easy to pour in and out
- Safety hinged lid
- Lime filter (removable)
- On/off switch (blue illuminated)
- Stainless steel heating element
- Automatic/manual switch-off
- External water level indicator
- Base station with cord storage
- Evaporation/overheating protection
- 230 V, 50 Hz, 2200 W



Automatic toaster TA 1577 CB

- Compact 2-slice toaster
- Cool touch housing
- Bun warmer (removable)
- Defrost/reheat/quick-stop function
- Continuously adjustable browning
- 3 indicator lights (blue illuminated)
- Automatic/manual switch-off
- Crumb drawer
- Cord storage
- 230 V, 50 Hz, 870 W max.



Coffee machine KA 1575 CB

- For 8–10 cups of coffee (approx. 1.25 litre)
- Anti-drip protection
- Swivel filter
- On/off switch with indicator light (blue illuminated)
- Water level indicator
- Heating plate with automatic switch-off
- 220–240 V, 50/60 Hz, 730–870 W

Automatic toaster TA 1577 CB

- Compact 2-slice toaster
- Cool touch housing
- Bun warmer (removable)
- Defrost/reheat/quick-stop function
- Continuously adjustable browning
- 3 indicator lights (blue illuminated)
- Automatic/manual switch-off
- Crumb drawer
- Cord storage
- 230 V, 50 Hz, 870 W max.

Kettle WK 1576 CB

- Max. capacity 1.7 litre
- Simple handling due to cable-free technology – easy to pour in and out
- Safety hinged lid
- Lime filter (removable)
- On/off switch (blue illuminated)
- Stainless steel heating element
- Automatic/manual switch-off
- External water level indicator
- Base station with cord storage
- Evaporation/overheating protection
- 230 V, 50 Hz, 2200 W



ST/WA 1364 CB



ST 1372 CB



TA 1371 CB

WA 1365 CB



KA 1370 CB

KA 1369 CB



KA 1367 CB





UM 1374 CB



AE 1917 CB



ESTATE

WKS 1356 CB



AE 1918 CB



WKS 1361 CB



3in1

Coffee machine
Automatic toaster
Kettle



Coffee machine KA 1501 CB

- For 8–10 cups of coffee
- Anti-drip protection
- On/off switch with indicator light
- Swivel filter
- Water level indicator
- Heating plate with automatic switch-off
- 220–240 V, 50/60 Hz, 730–870 W
- WxHxD approx. 210 x 300 x 220 mm

Kettle WK 1502 CB

- Max. capacity 1.7 litre
- Cordless, for easy using
- Nylon filter (removable)
- On/off switch with indicator light
- Automatic/manual switch-off
- 2 external water level indicators
- Evaporation/overheating protection
- 220–240 V, 50 Hz, 1850–2200 W
- WxHxD approx. 250 x 265 x 135 mm

Automatic toaster TA 1503 CB

- 2-slice toaster
- Cool touch housing
- Continuously adjustable thermostat
- Defrost/reheat/quick-stop function
- Lift function
- Crumb drawer (removable)
- Bun warmer (integrated)
- Base station with cord storage
- 230 V, 50 Hz, 800 W
- WxHxD approx. 275 x 180 x 180 mm

FS 1500 CB Breakfast-Set black

● Art. no. 615 001
EAN 4 004 470 150 018

PU 4

- Sales Packaging
WxHxD approx. 515 x 312 x 240 mm





Coffee machine
KA 1580 CB

- For 8–10 cups of coffee (approx. 1.25 litre)
- Stainless steel insert
- Anti-drip protection
- Filter holder (removable)
- On/off switch with indicator light (blue illuminated)
- Water level indicator
- Heating plate with automatic switch-off
- 220–240 V, 50/60 Hz, 1000 W



Automatic toaster
TA 1582 CB

- 2-slice toaster
- Stainless steel insert
- Cool touch housing
- Bun warmer (integrated)
- Defrost/reheat/quick-stop function
- Continuously adjustable thermostat
- 3 indicator lights (blue illuminated)
- Centring function
- Automatic/manual switch-off
- Crumb drawer
- Cord storage
- 220–240 V, 50/60 Hz, 720–850 W



Kettle
WKS 1581 CB

- Max. capacity 1.5 litre
- Stainless steel insert
- Simple handling due to cable-free technology – easy to pour in and out
- 360° connector
- Lockable safety hinged lid with one-handed operation
- Lime filter (removable)
- On/off switch (blue illuminated)
- Concealed stainless steel heating element
- Automatic/manual switch-off
- 2 external water level indicators
- Base station with cord storage
- Evaporation/overheating protection
- 220–240 V, 50/60 Hz, 1850–2200 W



| ETM TESTMAGAZIN • URTEIL | |
|---|---------------|
| Bomann KA 180 CB 1-Tassen Kaffeeautomat | |
| GUT | 81,3 % |
| Im Test: 6 Coffee to go-Maschinen Testurteile: 2x sehr gut, 4x gut | Heft 05/2015 |



14

1-cup coffee machine KA 180 CB

- „Coffee to go“ – simple, quick, and fresh, with the familiar taste of an aromatic filter coffee
- Ideal for camping, in the office, at home or on the way
- Incl. thermo stainless steel cup with drink opening and heat insulated aroma seal lid
- 300 ml capacity
- Permanent nylon filter (removable)
- Cup fits virtually all standard cup holders
- Rubberized „Soft Touch“ handle
- On/off switch
- Automatic power off
- Indicator light
- 220–240 V, 50 Hz, 420 W
- W x H x D approx. 155 x 235 x 150 mm

1 cup coffee machine KA 201 CB

- 1 cup coffee machine for filter coffee
- Space-saving design (ideal when out and about)
- Includes one ceramic cup
- Permanent nylon filter (removable)
- On/off switch with indicator light
- Automatic power off
- Non-slip tray (removable)
- 220–240 V, 50 Hz, 270–330 W
- W x H x D approx. 130 x 175 x 155 mm

Coffee machine KA 165 CB

- For 10–12 cups of coffee (approx. 1.5 litre)
- Anti-drip protection
- Swivel filter
- On/off switch with indicator light
- Water level indicator
- Heating plate with automatic switch-off
- Transparent water container
- Evaporation protection
- 230 V, 50 Hz, 800 W
- W x H x D approx. 165 x 285 x 225 mm

● Art. no. 601 801
EAN 4 004 470 018 011

PU 6



● Art. no. 602 011
EAN 4 004 470 020 113

PU 6



● Art. no. 601 650
EAN 4 004 470 016 505

PU 6





Coffee machine
KA 1575 CB

- For 8–10 cups of coffee (approx. 1,25 litre)
- Anti-drip protection
- Swivel filter
- On/off switch with indicator light (blue illuminated)
- Water level indicator
- Heating plate with automatic switch-off

- 220–240 V, 50/60 Hz, 730–870 W
- WxHxD approx. 165 x 300 x 250 mm

Coffee machine
KA 183 CB

- For 12–14 cups of coffee (approx. 1.5 litre)
- Anti-drip protection
- Filter holder (removable)
- On/off switch (illuminated)
- Water level indicator
- Heating plate with automatic switch-off
- Cord storage

- 230 V, 50 Hz, 900 W
- WxHxD approx. 190 x 330 x 205 mm

Coffee machine
KA 1580 CB

- For 8–10 cups of coffee (approx. 1.25 litre)
- Stainless steel insert
- Anti-drip protection
- Filter holder (removable)
- On/off switch with indicator light (blue illuminated)
- Water level indicator
- Heating plate with automatic switch-off

- 220–240 V, 50/60 Hz, 1000 W
- WxHxD approx. 185 x 310 x 260 mm

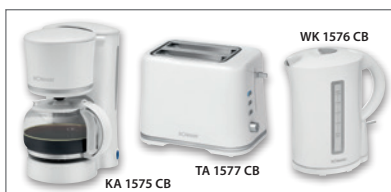

Can also be combined as a suitable breakfast set



Can also be combined as a suitable breakfast set

● Art. no. 615 750
EAN 4 004 470 157 505 PU 6
● Art. no. 615 751
EAN 4 004 470 157 512 PU 6



● Art. no. 601 830
EAN 4 004 470 018 301 PU 6
● Art. no. 601 833
EAN 4 004 470 018 332 PU 6



● Art. no. 615 801
EAN 4 004 470 158 014 PU 6





Coffee machine
KA 1369 CB

- For 12–14 cups of coffee (approx. 1.5 litre)
- High-quality stainless steel application
- Anti-drip protection
- Filter holder (removable)
- On/off switch with indicator light (blue illuminated)
- Water level indicator
- Heating plate with automatic switch-off
- 220–240 V, 50/60 Hz, 900 W
- W x H x D approx. 180 x 325 x 260 cm



Coffee machine
KA 1565 CB

- For 8–10 cups of coffee (approx. 1.2 litre)
- Stainless steel insert and lid
- Anti-drip protection
- Filter holder (removable)
- On/off switch with indicator light
- Water level indicator
- Heating plate with automatic switch-off
- 220–240 V, 50 Hz, 900 W
- W x H x D approx. 195 x 335 x 220 mm



Coffee machine
KA 1367 CB

- For 15 cups of coffee (approx. 1.7 litre)
- Stainless steel front
- Programmable 24-hour LCD digital timer
- Anti-drip protection
- Filter holder (removable)
- 4 control buttons (illuminated)
- Heating plate with automatic switch-off
- Water level indicator
- 230 V, 50 Hz, 1000 W
- W x H x D approx. 220 x 375 x 240 mm



Can also be combined as a suitable kitchen set



Programmable 24-hour LCD digital timer

Art. no. 613 691
EAN 4 004 470 136 913

PU 4



Art. no. 615 651
EAN 4 004 470 156 515

PU 4



Art. no. 613 671
EAN 4 004 470 136 715

PU 4





Thermo coffee machine
KA 168 CB

- For 8-10 cups of coffee (approx. 1.0 litre)
- Thermo jug (double-walled)
- Anti-drip protection
- Filter holder (removable)
- On/off switch with indicator light
- Automatic power off
- Water level indicator

- 220-240 V, 50/60 Hz, 730-870 W
- WxHxD approx. 185 x 340 x 210 mm

Thermo coffee machine
KA 1370 CB

- For 8-10 cups of coffee (approx. 1.2 litre)
- Stainless steel thermo jug (double-walled) with aroma seal – drinks remain hot for longer
- High-quality stainless steel application
- Anti-drip protection
- Filter holder (removable)
- On/off switch with indicator light (blue illuminated)
- Automatic power off
- Water level indicator

- 220-240 V, 50 Hz, 800 W
- WxHxD approx. 180 x 325 x 260 cm



Double-walled thermo jug with aroma seal – drinks remain hot for longer

NEW! Espresso machine
ES 1185 CB

- Espresso and cappuccino pump machine
- Stainless steel front
- Swiveling stainless steel steam nozzle with foaming and hot water function
- Steam volume steplessly adjustable
- Steam nozzle tip removable for easy cleaning
- Cup warming function with stainless steel insert
- Constant pump pressure of 15 bar
- 1.6 litre transparent water tank (removable)
- External water level indicator
- Collection cup with stainless steel drip grid (removable)
- 2 indicator lights
- Automatic shut-off
- Operational readiness indication
- Accessories: 2 filter holders (1 and 2 cups), coffee scoop, tamper

- 220-240 V, 50 Hz, 850 W
- WxHxD approx. 250 x 295 x 280 mm



Cup warming function



Swiveling stainless steel steam nozzle with foaming and hot water function

● Art. no. 601 680
EAN 4 004 470 016 802 PU 6
● Art. no. 601 683
EAN 4 004 470 016 871 PU 6

● Art. no. 613 701
EAN 4 004 470 137 019 PU 4

● Art. no. 611 851
EAN 4 004 470 118 513 PU 2





Stainless steel housing



Cold and warm foaming function

Coffee grinder KSW 445 CB

- Electric coffee mill with beater
 - Stainless steel beater blade
 - Stainless steel bean container, hygienic and with aroma protection
 - Transparent lid
 - Capacity 40 g – for 20 cups of coffee
 - With 120 watt motor
 - Safety circuit – operation only possible with lid in place
 - Safety pushbutton also for pulsed operation
 - Degree of grinding can be selected by the length of operation
 - Cord storage
- 220–240, 50 Hz, 120 W
 - WxHxD approx. 100 x 200 x 100 mm

Coffee grinder KSW 446 CB

- Electric coffee mill with beater
 - Stainless steel beater blade
 - Stainless steel bean container, hygienic and with aroma protection
 - Transparent lid
 - Capacity 40 g – for 20 cups of coffee
 - With 120 watt motor
 - Safety circuit – operation only possible with lid in place
 - Safety pushbutton also for pulsed operation
 - Degree of grinding can be selected by the length of operation
 - Cord storage
- 220–240 V, 50 Hz, 120 W
 - WxHxD approx. 100 x 200 x 100 mm

NEW! Milk frother MS 479 CB

- Integrated heating function
 - Creates foamy milk in seconds
 - Also suitable for hot and cold chocolate
 - Stainless steel container (700 ml)
 - Insulated soft-touch coating
 - Foamed milk volume: approx. 500 ml
 - Simple handling due to cable-free technology, plug connection rotates through 360°
 - Electronic 2-function switch
 - Froth the milk warm
 - Froth the milk cold – ideal for iced coffee
 - Heat the milk
 - Built-in heating element
 - Automatic switch-off function
 - Incl. lid with splash guard function
 - Additional stirrer for hot drinks without frothing (e.g. cocoa)
 - Mixing bowl and lid removable for easy cleaning
- 220–240 V, 50 Hz, 550–650 W
 - WxHxD approx. 105 x 240 x 105 mm

Art. no. 604 451
EAN 4 004 470 044 515

PU 6



Art. no. 604 460
EAN 4 004 470 044 607

PU 6



Art.-Nr. 604 701
EAN 4 004 470 047 011

PU 4





**Cold and warm
foaming function**



Glass milk frother MS 376 CB

- No preheating of the milk thanks to the integrated heating function
- Creates foamy milk in seconds
- Also suitable for hot and cold chocolate
- Glass container (750 ml) with stainless steel handle
- Amount of milk foam: approx. 300 ml
- Simple handling due to cable-free technology, plug connection rotates through 360°
- Electronic 3 function switch
 - Froth the milk warm
 - Froth the milk cold – ideal for iced coffee
 - Heat the milk
- Built-in heating element
- Automatic switch-off function
- Incl. lid with splash guard function
- Additional stirrer hot drinks without foaming (e.g. cacao)
- Glass container and lid removable for easy cleaning
- 220–240 V, 50 Hz, 600–650 W
- WxHxD approx. 120 x 180 x 175 mm

Milk frother MS 344 CB

- Creates foamy milk in seconds
- Soft touch housing
- Stainless steel whisk
- Easy to clean
- Battery operation: 2 x 1,5 V AA/UM 3 (batteries not included)
- WxHxD approx. 47 x 225 x 32 mm

Kettle WK 5024 CB

- Max. capacity 1.0 litre
- Simple handling due to cable-free technology – easy to pour in and out
- Safety hinged lid with one-handed operation
- Lime filter (removable)
- On/off switch (illuminated)
- Stainless steel heating element
- Automatic/manual switch-off
- 2 external water level indicators
- Rubber profile on the handle
- Incl. base station
- Evaporation/overheating protection
- 220–240 V, 50 Hz, 1850–2200 W
- WxHxD approx. 185 x 220 x 115 mm



Kettle
WK 5011 CB

- Max. capacity 1.7 litre
 - Simple handling due to cable-free technology – easy to pour in and out
 - Safety hinged lid with one-handed operation
 - Lime filter (removable)
 - On/off switch (illuminated)
 - Stainless steel heating element
 - Automatic/manual switch-off
 - 2 external water level indicators
 - Rubber profile on the handle
 - Base station with cord storage
 - Evaporation/overheating protection
- 220–240 V, 50 Hz, 1850–2200 W
■ WxHxD approx. 220 x 255 x 140 mm

Kettle
WK 5011 CB

- Max. capacity 1.7 litre
 - Simple handling due to cable-free technology – easy to pour in and out
 - Safety hinged lid with one-handed operation
 - Lime filter (removable)
 - On/off switch (illuminated)
 - Stainless steel heating element
 - Automatic/manual switch-off
 - 2 external water level indicators
 - Rubber profile on the handle
 - Base station with cord storage
 - Evaporation/overheating protection
- 220–240 V, 50 Hz, 1850–2200 W
■ WxHxD approx. 220 x 255 x 140 mm

Kettle
WK 1576 CB

- Max. capacity 1.7 litre
 - Simple handling due to cable-free technology – easy to pour in and out
 - Safety hinged lid
 - Lime filter (removable)
 - On/off switch (blue illuminated)
 - Stainless steel heating element
 - Automatic/manual switch-off
 - External water level indicator
 - Base station with cord storage
 - Evaporation/overheating protection
- 220–240 V, 50/60 Hz, 1850–2200 W
■ WxHxD approx. 220 x 235 x 125 mm



Can also be combined as a suitable kitchen set



Can also be combined as a suitable breakfast set

- Art. no. 650 110
EAN 4 004 470 501 100 PU 6
- Art. no. 650 113
EAN 4 004 470 501 131 PU 6
- Art. no. 650 111
EAN 4 004 470 501 117 PU 6



- Art. no. 650 118
EAN 4 004 470 501 186 PU 6
- Art. no. 650 119
EAN 4 004 470 501 193 PU 6
- Art. no. 650 117
EAN 4 004 470 501 179 PU 6



- Art. no. 615 760
EAN 4 004 470 157 604 PU 6
- Art. no. 615 761
EAN 4 004 470 157 611 PU 6





Kettle
WK 5012 CB

- Max. capacity 1.8 litre
 - Simple handling due to cable-free technology – easy to pour in and out
 - 360° connector
 - Lockable safety hinged lid with one-handed operation
 - Lime filter (removable)
 - On/off switch (illuminated)
 - Concealed stainless steel heating element
 - Automatic/manual switch-off
 - 2 external water level indicators
 - Base station with cord storage
 - Overheating protection
- 220–240 V, 50 Hz, 1850–2200 W
■ W x H x D approx. 225 x 255 x 150 mm

Kettle
WKS 1581 CB

- Max. capacity 1.5 litre
 - Stainless steel insert
 - Simple handling due to cable-free technology – easy to pour in and out
 - 360° connector
 - Lockable safety hinged lid with one-handed operation
 - Lime filter (removable)
 - On/off switch (illuminated)
 - Concealed stainless steel heating element
 - Automatic/manual switch-off
 - 2 external water level indicators
 - Base station with cord storage
 - Evaporation/overheating protection
- 220–240 V, 50/60 Hz, 1850–2200 W
■ W x H x D approx. 155 x 245 x 215 mm

Kettle
WK 1566 CB

- Max. capacity 1.7 litre
 - Simple handling due to cable-free technology – easy to pour in and out
 - 360° connector
 - Safety hinged lid with stainless steel insert and one-handed operation
 - Lime filter (removable)
 - On/off switch
 - Concealed stainless steel heating element
 - Automatic/manual switch-off
 - 2 external water level indicators (illuminated)
 - Base station with cord storage
 - Overheating protection
- 220–240 V, 50 Hz, 1850–2200 W
■ W x H x D approx. 220 x 235 x 160 mm



Can also be combined as a suitable breakfast set



Can also be combined as a suitable kitchen set

● Art. no. 650 120
EAN 4 004 470 501 209 PU 6
● Art. no. 650 123
EAN 4 004 470 501 216 PU 6

● Art. no. 615 811
EAN 4 004 470 158 113 PU 6

● Art. no. 615 661
EAN 4 004 470 156 614 PU 4
● Art. no. 615 664
EAN 4 004 470 156 645 PU 4





Stainless steel



Stainless steel



Stainless steel

Travel kettle
WKR 1162 CB

- Ideal when traveling and on the move
- Max. capacity 0.5 litre
- Stainless steel housing
- Incl. 2 cups à 170 ml, transport / travel bag and coffee spoon
- Concealed stainless steel heating element
- Indicator light
- Automatic switch-off
- Evaporation/overheating protection

- 120/230 V, 50/60 Hz, 1000 W
- WxHxD approx. 160 x 170 x 105 mm



Incl. transport / travel bag



Incl. 2 cups à 170 ml + coffee spoon

Kettle
WKS 1361 CB

- Max. capacity 1.0 litre
- Stainless steel thermo housing
- Simple handling due to cable-free technology – easy to pour in and out
- 360° connector
- Lockable safety hinged lid
- Lime filter (removable)
- On/off switch
- Concealed stainless steel heating element
- Automatic/manual switch-off
- Water level indicator
- Base station with cord storage
- Evaporation/overheating protection

- 220–240 V, 50/60 Hz, 1850–2200 W
- WxHxD approx. 220 x 195 x 150 mm

Kettle
WKS 5010 CB

- Max. capacity 1.7 litre
- Simple handling due to cable-free technology – easy to pour in and out
- 360° connector
- Lockable safety hinged lid
- Lime filter (integrated)
- On/off switch (illuminated)
- Stainless steel body
- Concealed stainless steel heating element
- Automatic/manual switch-off
- Water level indicator
- Cord storage
- Evaporation/overheating protection

- 220–240 V, 50 Hz, 2000–2400 W
- WxHxD approx. 230 x 250 x 145 mm

● Art. no. 611 621
EAN 4 004 470 116 212 PU 6



● Art. no. 613 611
EAN 4 004 470 136 111 PU 6



● Art. no. 650 100
EAN 4 004 470 501 001 PU 6
● Art. no. 650 103
EAN 4 004 470 501 032 PU 6
● Art. no. 650 101
EAN 4 004 470 501 018 PU 6





Stainless steel

Kettle
WKS 1356 CB

- Max. capacity 1.7 litre
 - Simple handling due to cable-free technology – easy to pour in and out
 - 360° connector
 - Lockable safety hinged lid
 - Lime filter (removable and washable)
 - On/off switch
 - Indicator light (blue illuminated)
 - Stainless steel thermo housing
 - Concealed stainless steel heating element
 - Automatic/manual switch-off
 - 2 external water level indicators
 - Base station with cord storage (stainless steel sheathed)
 - Evaporation/overheating protection
- 220–240 V, 50 Hz, 1850–2200 W
■ WxHxD approx. 220 x 250 x 145 mm



Stainless steel

Water kettle
WKS 5031 CB

- Max. capacity 1.8 litre
 - Simple handling due to cable-free technology – easy to pour in and out
 - 360° connector
 - Lime filter (removable, washable)
 - On/off switch (illuminated)
 - Concealed stainless steel heating element
 - Stainless steel water jug
 - Automatic/manual switch-off
 - External water level indicator
 - Base station with cord storage
 - Evaporation/overheating protection
- 220–240 V, 50 Hz, 1850–2200 W
■ WxHxD approx. 245 x 295 x 225 mm



Stainless steel

Water kettle
WK 5025 CB

- Max. capacity 1.8 litre
 - Simple handling due to cable-free technology – easy to pour in and out
 - 360° connector
 - Lime filter (removable, washable)
 - On/off switch
 - Concealed stainless steel heating element
 - Stainless steel water jug
 - Automatic/manual switch-off
 - External water level indicator
 - Base station with cord storage
 - Evaporation/overheating protection
- 220–240 V, 50 Hz, 1850–2200 W
■ WxHxD approx. 200 x 285 x 230 mm



External water level indicator



External water level indicator

Art. no. 613 561
EAN 4 004 470 135 619

PU 6



Art. no. 650 316
EAN 4 004 470 503 166
Art. no. 650 311
EAN 4 004 470 503 111

PU 4

PU 4



Art. no. 650 251
EAN 4 004 470 502 510

PU 4





Glass kettle WK 5023 G CB

- Max. capacity 1.7 litre
- Glass/stainless steel housing
- Water container made of heat resistant safety glass
- Simple handling due to cable-free technology – easy to pour in and out
- 360° connector
- On/off switch
- Concealed stainless steel heating element
- Automatic/manual switch-off
- External water level indicator
- Base station with cord storage (stainless steel sheathed)
- Evaporation/overheating protection
- 220–240 V, 50 Hz, 1850–2200 W
- W x H x D approx. 220 x 240 x 150 mm

NEW! Electric glass kettle WKS 5032 G CB

- Max. capacity 1.5 litre
- Glass/stainless steel housing
- Lockable stainless steel lid with single-handed operation
- Water container made of heat-resistant safety glass (blue illuminated)
- Simple handling due to cable-free technology – easy to pour in and out
- 360° connector
- On/off switch
- Concealed stainless steel heating element
- Automatic/manual switch-off
- External water level indicator
- Base station with cord storage (stainless steel sheathed)
- Evaporation/overheating protection
- 220–240 V, 50/60 Hz, 1850–2200 W
- W x H x D approx. 220 x 240 x 130 mm

Automatic toaster TA 246 CB

- Compact 2-slice toaster
- Cool touch housing
- Bun warmer (integrated)
- Defrost/reheat/quick-stop function
- Continuously adjustable thermostat
- 2 indicator lights
- Automatic/manual switch-off
- Crumb drawer
- Base station with cord storage
- 220–240 V, 50/60 Hz, 600–700 W
- W x H x D approx. 285 x 240 x 165 mm



Water container made of heat-resistant safety glass (blue illuminated)

● Art. no. 650 231
EAN 4 004 470 502 312 PU 4



● Art. no. 650 321
EAN 4 004 470 503 210 PU 4



● Art. no. 602 460
EAN 4 004 470 024 609 PU 6
● Art. no. 602 463
EAN 4 004 470 024 630 PU 6





Automatic toaster
TA 1577 CB

- Compact 2-slice toaster
 - Cool touch housing
 - Bun warmer (removable)
 - Defrost/reheat/quick-stop function
 - Continuously adjustable browning
 - 3 indicator lights (blue illuminated)
 - Automatic/manual switch-off
 - Crumb drawer
 - Cord storage
- 220–240 V, 50/60 Hz, 730–870 W
■ WxHxD approx. 260 x 170 x 145 mm

Automatic toaster
TA 1582 CB

- 2-slice toaster
 - Stainless steel insert
 - Cool touch housing
 - Bun warmer (integrated)
 - Defrost/reheat/quick-stop function
 - Continuously adjustable thermostat
 - 3 indicator lights (blue illuminated)
 - Centring function
 - Automatic/manual switch-off
 - Crumb drawer
 - Cord storage
- 220–240 V, 50/60 Hz, 720–850 W
■ WxHxD approx. 300 x 175 x 170 mm

Automatic toaster
TA 1567 CB

- 2-slice toaster
 - Stainless steel insert
 - Cool touch housing
 - Bun warmer (removable)
 - Defrost/reheat/quick-stop function
 - Continuously adjustable thermostat
 - 3 indicator lights
 - Centring function
 - Automatic/manual switch-off
 - Crumb drawer
 - Cord storage
- 220–240 V, 50 Hz, 680–800 W
■ WxHxD approx. 285 x 185 x 170 mm

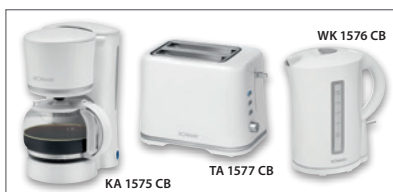

Can also be combined as a suitable breakfast set



Can also be combined as a suitable breakfast set



Can also be combined as a kitchen breakfast set

● **Art. no. 615 770**
EAN 4 004 470 157 703 PU 6
● **Art. no. 615 771**
EAN 4 004 470 157 710 PU 6



● **Art. no. 615 821**
EAN 4 004 470 158 212 PU 6



● **Art. no. 615 671**
EAN 4 004 470 156 713 PU 4
● **Art. no. 615 674**
EAN 4 004 470 156 744 PU 4





 Stainless steel housing

26

Automatic toaster
TA 1371 CB

- 2-slice toaster
- Stainless steel housing
- Bun warmer (removable)
- Defrost/reheat/quick-stop function (blue illuminated)
- Continuously adjustable thermostat
- Centring function
- Automatic/manual switch-off
- Crumb drawer
- Cord storage

- 220–240 V, 50/60 Hz, 750–850 W
- WxHxD approx. 270 x 180 x 150 mm

Automatic toaster
TA 245 CB

- 4-slice long-slot toaster
- Heat-insulated cool touch housing
- Bun warmer (removable)
- Defrost/reheat/quick-stop function
- Continuously adjustable browning
- 3 LED indicator lights
- Automatic switch-off
- Crumb drawer
- Cord storage

- 220–240 V, 50/60 Hz, 1200–1400 W
- WxHxD approx. 375 x 175 x 165 mm



Defrost/reheat/
quick-stop function
(blue illuminated)

● Art. no. 613 711
EAN 4 004 470 137 118 PU 4



● Art. no. 602 450
EAN 4 004 470 024 500 PU 6





Waffle maker

WA 5018 CB

- Large baking plates: approx. Ø 18 cm (non-stick coated)
 - Heat insulated handle
 - Continuously adjustable thermostat
 - 2 indicator lights for power and heating (baking lights)
 - High stability due to rubberized feet
 - Overheating protection
- 220–240 V, 50 Hz, 1200 W
 - WxHxD approx. 205 x 115 x 250 mm

Waffle maker

WA 1365 CB

- Stainless steel insert
 - Large baking plates: approx. Ø 18 cm (non-stick coated)
 - Heat insulated handle
 - Continuously adjustable thermostat
 - 2 indicator lights for power and heating (baking lights)
 - Overheating protection
- 220–240 V, 50/60 Hz, 1000 W
 - WxHxD approx. 200 x 100 x 260 mm



Stainless steel insert

● Art. no. 650 180
 EAN 4 004 470 616 798 PU 6
 ● Art. no. 650 181
 EAN 4 004 470 501 810 PU 6



● Art. no. 613 651
 EAN 4 004 470 616 811 PU 4





28

Waffle maker WA 5030 CB

- Stainless steel insert
- 2 large baking plates (non-stick coated)
- 2 waffles for each baking procedure
- Heat insulated handle
- Continuously adjustable thermostat
- 2 indicator lights for power and heating (baking lights)
- High stability due to rubberized feet
- Overheating protection
- Cord storage
- 220–240 V, 50 Hz, 1200 W
- WxHxD approx. 350 x 105 x 230 mm

Ice cream cone maker HA 5017 CB

- Large baking plate: approx. Ø 18 cm (non-stick coated)
- Heat insulated handle
- Continuously adjustable thermostat
- 2 indicator lights for power and heating (baking lights)
- High stability due to rubberized feet
- Incl. squirrel cone
- Overheating protection
- 220–240 V, 50 Hz, 1200 W
- WxHxD approx. 205 x 115 x 250 mm

Crêpe maker CM 2221 CB

- Large baking plate: approx. Ø 29 cm (non-stick coated)
- Paper-thin crêpes, quickly and easily prepared
- Heat-insulated plastic base
- Continuously adjustable thermostat
- 2 indicator lights for power and heating (baking lights)
- Base station with cord storage
- Incl. batter distributor
- 220–240 V, 50/60 Hz, 900 W
- WxHxD approx. 325 x 80 x 370 mm



Stainless steel insert



Incl. squirrel cone

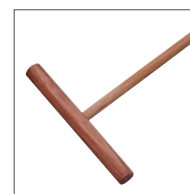

Incl. batter distributor

● Art. no. 650 301
EAN 4 004 470 503 012

PU 4



● Art. no. 650 171
EAN 4 004 470 616 835

PU 6



● Art. no. 622 211
EAN 4 004 470 222 111

PU 4





Muffin maker
MM 5020 CB

- For baking up to 7 muffins
 - Muffin diameter approx. 4.5 cm
 - Baking surfaces non-stick coated
 - Heat insulated handle
 - 2 indicator lights for power and heating (baking lights)
 - High stability due to rubberized feet
 - Overheating protection
- 220–240 V, 50/60 Hz, 900 W
 - W x H x D approx. 225 x 115 x 225 mm

Sandwich toaster
ST 5016 CB

- Triangular sandwich plates
 - Non-stick coating
 - Heat insulated handle
 - Automatic temperature controller
 - 2 indicator lights for power and heating (baking lights)
 - Locking system
 - Safety shutdown
 - Overheating protection
- 220–240 V, 50/60 Hz, 750 W
 - W x H x D approx. 230 x 80 x 230 mm

Sandwich toaster
ST 1372 CB

- Stainless steel insert
 - Triangular sandwich plates
 - Non-stick coating
 - Heat insulated handle
 - Automatic temperature control
 - 2 indicator lights for power and heating (baking lights)
 - High stability due to rubberized feet
 - Locking system
 - Overheating protection
- 220–240 V, 50/60 Hz, 750 W
 - W x H x D approx. 235 x 95 x 235 mm



Stainless steel insert

● **Art. no. 650 201**
EAN 4 004 470 616 859 PU 6



● **Art. no. 650 160**
EAN 4 004 470 501 605 PU 6
● **Art. no. 650 163**
EAN 4 004 470 501 636 PU 6



● **Art. no. 613 721**
EAN 4 004 470 637 359 PU 6





30

Sandwich toaster ST 1472

- 4-slice sandwich toaster
- Stainless steel insert
- Triangular sandwich plates
- Non-stick coating
- Heat insulated handle
- Automatic temperature control
- 2 indicator lights for power and heating (baking lights)
- High stability due to rubberized feet
- Locking system
- Overheating protection and overtemperature protection
- 220–240 V, 50/60 Hz, 1200 W
- WxHxD approx. 270 x 105 x 325 mm

Multi grill ST/WA 1364 CB

- Sandwich toaster, waffle maker and contact grill
- Versatile use by three different removable plates (sandwich/waffle/grill plates), e.g. for Belgian waffles and tasty sandwich variations, as well as for fast two-sided contact grilling
- Stainless steel insert
- Baking plates non-stick coated and changeable
- Heat insulated handle
- 2 indicator lights for power and heating (baking lights)
- High stability due to rubberized feet
- Locking system
- Overheating protection
- 230 V, 50/60 Hz, 650 W
- WxHxD approx. 230 x 100 x 225 mm

Multi grill MG 2251 CB

- Multi grill for double-sided, fat-free grilling
- 700 watts
- Stainless steel housing
- Short cooking times
- Non-stick grill plates with extra deep grooves for strong grill pattern
- Heat insulated handle
- Indicator light
- Grilling surfaces: 23 x 14.5 cm
- Cord storage
- Versatile, can be used for e.g. panini, steaks, fish or vegetables
- 220–240 V, 50/60 Hz, 700W
- WxHxD approx. 270 x 95 x 230 mm



Stainless steel insert



Stainless steel insert



Sandwich plates, waffle plates, grill plates



Stainless steel housing

Art. no. 614 720
EAN 4 004 470 637 366

PU 4



Art. no. 613 641
EAN 4 004 470 616 781

PU 4



Art. no. 622 511
EAN 4 004 470 225 112

PU 6





Ice cube maker
EWB 1027 CB

- Compact ice cube maker without complicated installation for producing ice cubes quickly and simply at the press of a button
- Ideal for home use, in offices, when camping or for small bars
- No water pipe required, simply fill water into the tank (2.2-l-water tank)
- Approx. 10–15 kg of ice cubes in 24 hours (approx. 90 g in 10 min – corresponding to 9 ice cubes)
- LED display and acoustic signal when the ice cube container is full or the water tank is empty
- Energy-saving mode – automatic switch-off at the end of the program
- On/off switch
- 3 indicator lights (ice full, empty water, operation)
- Visual check through viewing window in the lid
- Low-noise
- 220–240 V, 50/60 Hz, 95 W (Cooling), 165 W (spending ice cubes)
- W x H x D approx. 245 x 330 x 370 mm



LED displays



For approx. 10–15 kg ice cubes

Soft ice cream maker
ICM 387 CB

- Soft ice cream maker with discharge valve for preparation of soft ice cream, ice cream, frozen yogurt, and sorbet
- Transparent lid with refill opening
- With portioner – ice dispensed directly from the machine
- On/off switch
- Incl. recipe suggestions
- For up to 1000 ml ice cream
- Double-walled ice cream maker with cold storage, removable for easy cleaning (H: 14 cm; Ø 17 cm)
- Stirring element with powerful, quiet motor
- High stability due to rubberized feet
- 220-240 V, 50 Hz, 18 W
- W x H x D approx. 220 x 440 x 225 mm



Soft ice cream maker with discharge valve

Yogurt maker
JM 1025 CB

- Easy preparation of up to 1.1 litres of yoghurt
- 7 practical portion jars with screw cap (capacity: 160 ml)
- On/off switch (illuminated)
- Transparent lid
- Additional jars in a set of 6 also available as an optional EG JM 3344, Product number: 251 125
- 220–240 V, 50 Hz, 15 W
- W x H x D approx. 240 x 150 x 265 mm

Suitable replacement jar:
EG JM 3344

Art. no.: 251 125
EAN: 4 006 160 511 253



Art. no. 610 271
EAN 4 004 470 102 710 PU 1



Art. no. 603 870
EAN 4 004 470 038 705 PU 2



Art. no. 610 250
EAN 4 004 470 102 505 PU 6



| | |
|--|---------------|
| PREIS-/LEISTUNGSSIEGER | |
| ETM TESTMAGAZIN · URTEIL | |
| Bomann MA 451 CB | |
| GUT | 83,6 % |
| Im Test: 10 Alleschneider Testurteile: 1x sehr gut, 8x gut, 1x ausreichend www.etm-testmagazin.de | Heft 10/2015 |



32

Egg boiler EK 5022 CB

- Preparation of up to 6 eggs
- Heating dish (non-stick coated)
- On/off switch (illuminated)
- Acoustic signal (buzzer)
- Removable egg holder
- Incl. measuring beaker with egg pricker
- 230 V, 50 Hz, 400 W
- WxHxD approx. 220 x 130 x 135 mm

Electric pepper/salt mill PSM 437 N CB

- High-quality precision ceramic grinder
- Stainless steel housing
- Adjustable ceramic grinder (from coarse to fine)
- Consistent grinding quality
- Simple refilling
- Single-handed operating
- Incl. light for optimum dosing of the condiment
- Battery-operated
- Battery operation: 4x1,5 V AA/Mignon/LR/AM3 (batteries not included)
- WxHxD approx. 45 x 220 x 45 mm

Metal food slicer MA 451 CB

- Big stainless steel blade (Ø 190 mm), rustproof
- Universal serrated blade
- Motor housing: aluminium die cast
- On/off switch
- Metal guiding rail
- Metallic guiding board
- Food grip with finger protection
- Continuously adjustable cutting size (0–15 mm)
- Tilted supporting table with stainless steel insert, tiltable for easy cleaning
- High stability due to suction feet
- 220–240 V, 50/60 Hz, 150 W
- WxHxD approx. 365 x 235 x 265 mm



- Art. no. 650 220
EAN 4 004 470 616 866 PU 6
- Art. no. 650 223
EAN 4 004 470 502 237 PU 6
- Art. no. 650 228
EAN 4 004 470 502 282 PU 6



- Art. no. 604 372
EAN 4 004 470 043 723 PU 6



- Art. no. 604 510
EAN 4 004 470 045 109 PU 2





Incl. transparent mixing vessel

| | | | |
|--|--|--|-----------|
| <p>Hand blender SM 354 CB</p> | <p>Hand blender SM 384 CB</p> | <p>NEW! Hand blender SM 401 CB</p> | <p>33</p> |
|--|--|--|-----------|

- Stainless steel cutting blade
- On/off switch (countersunk)
- Incl. transparent mixing vessel (500 ml)
- Hanging loop
- Wall holder plus attachment materials
- 220–240 V, 50 Hz, 180 W
- W x H x D approx. 80 x 330 x 80 mm

- Stainless steel cutting blade (rustproof)
- On/off switch (countersunk)
- Powerful 180 watt motor
- Incl. transparent mixing vessel (500 ml)
- Hanging loop
- 220–240 V, 50 Hz, 180 W
- W x H x D approx. 80 x 330 x 80 mm

- Soft touch housing
- Stainless steel insert
- 2-level pushbutton switch
- Powerful 600 watt motor
- Stainless steel cutting blade
- Removable stainless steel hand blender
- Ergonomically shaped handle
- Hanging loop
- 220–240 V, 50/60 Hz, 600 W
- W x H x D approx. 65 x 370 x 65 mm



Incl. transparent mixing vessel (500 ml)



Can also be combined as a suitable kitchen set

● **Art. no. 603 540**
EAN 4 004 470 035 407 PU 12



● **Art. no. 603 842**
EAN 4 004 470 038 422 PU 8
● **Art. no. 603 846**
EAN 4 004 470 038 460 PU 8
● **Art. no. 603 848**
EAN 4 004 470 038 484 PU 8



● **Art. no. 604 011**
EAN 4 004 470 040 111 PU 6





3in1

Hand blender set SMS 349 CB

- Hand blender set – stainless steel hand blender, multiple chopper and whisk in one
- Working container with scale (0,5 litre)
- Powerful 200 watt motor
- 2 speeds
- Removable metal whisk
- Ergonomically shaped rubberised handle for easier handling
- Holder for metal whisk and stainless steel hand blender
- Incl. mixing vessel with scale (0.7 litre)
- Hanging loop
- 220–240 V, 50/60 Hz, 200 W
- WxHxD approx. 160 x 370 x 150 mm



4in1

Hand blender set SMS 374 CB

- Hand blender set (hand blender, whisk, ice-crusher, food processor)
- 7 functional options
- Stainless steel housing
- Powerful 750 watt motor
- Incl. ice-crush function
- Variable speed regulation, illuminated in blue
- Incl. turbo setting for heavy applications
- Soft-touch press-button
- Ergonomically shaped, rubberized handle for easier handling
- Stainless steel mixing rod and metal whisk, detachable
- Work container with scale and refill opening (1.25 litre capacity)
- High-grade, interchangeable attachments from stainless steel for chopping and grating
- Attachments: grating, cutting and potato-grating insert, chopper, transparent mixing container with scale (0.6 litre)
- Quick and easy assembly of the accessories
- 220–240 V, 50/60 Hz, 750 W
- WxHxD approx. 70 x 390 x 70 mm



Variable speed regulation

Incl. whisk

Art. no. 603 491
EAN 4 004 470 034 912

PU 6



Art. no. 603 741
EAN 4 004 470 037 418

PU 4





2in1

Multi chopper
& ice-crusher

Multi express ME 467 CB

- Electrical shredding unit "Multi Express"
- Large and changeable high-quality drum attachments made of stainless steel, for quick and easy cutting or grating
- Easy handling
- 5 functions:
 - cutting (fine/coarse) of, for example, onions, cucumbers
 - grating (fine/coarse) of, for example, carrots, radishes
 - shredding for example of parmesan, nuts, potatoes
- Powerful 150 W motor
- Large refill opening (ca. Ø 60 mm)
- Wide discharge opening (ca. Ø 80 mm)
- Accessories: 2 cutting attachments (fine/coarse), 2 grating attachments (fine/coarse), 1 shredding attachment
- 220–240 V, 50/60 Hz, 150 W
- WxHxD approx. 150 x 275 x 230 mm

Multi chopper MZ 449 CB

- Mixing bowl (1 litre capacity)
- Removable chopping blade (rustproof)
- Incl. ice-crusher function
- Safe base
- Easy to clean
- 220–240 V, 50/60 Hz, 250 W
- WxHxD approx. 175 x 220 x 175 mm

35

Fine cutting
e.g. onionsCoarse cutting
e.g. cucumbersFine grating
e.g. potatoesCoarse grating
e.g. carrotsShredding
e.g. parmesan

Art. no. 604 670
EAN 4 004 470 046 700

PU 4



Art. no. 604 490
EAN 4 004 470 044 904

PU 6





2in1

**Multi chopper
& ice-crusher**



2in1

**Multi chopper
& ice-crusher**

36

Multi chopper
MZ 449 CB

- Mixing bowl (1 litre capacity)
- Removable chopping blade (rustproof)
- Incl. ice-crusher function
- Safe base
- Easy to clean
- 220–240 V, 50/60 Hz, 250 W
- W x H x D approx. 175 x 220 x 175 mm

Multi chopper
MZ 450 CB

- Mixing bowl made of glass (1.2 litre capacity)
- Removable chopping blade (stainless steel, rustproof)
- 2-level pulse switching
- Incl. ice-crusher function
- Safe base
- Easy to clean
- 220–240 V, 50/60 Hz, 300 W
- W x H x D approx. 175 x 265 x 175 mm



Can also be combined as a suitable kitchen set

- **Art. no. 604 492**
EAN 4 004 470 044 928 **PU 6**
- **Art. no. 604 496**
EAN 4 004 470 044 966 **PU 6**
- **Art. no. 604 498**
EAN 4 004 470 044 980 **PU 6**

- **Art. no. 604 500**
EAN 4 004 470 045 000 **PU 6**





2in1

Multi chopper
& ice-crusher



2in1

Multi chopper
& ice-crusher



Multi chopper
MZ 464 CB

- Large mixing bowl made of glass (1.5 litres capacity)
 - 2 removable chopping blades (stainless steel, rustproof)
 - 2-level pulse switching
 - Incl. ice-crusher function
 - Mixing bowl suitable for microwave oven
 - Stainless steel insert
 - Safe base
 - Easy to clean
- 220–240 V, 50/60 Hz, 300 W
 - W x H x D approx. 175 x 280 x 175 mm

Multi chopper
MZ 1568 CB

- Mixing bowl made of glass (1.2 litre capacity)
 - 2 removable chopping blades (stainless steel, rustproof)
 - Incl. ice-crusher function
 - Stainless steel insert
 - Safe base
 - Easy to clean
- 220–240 V, 50 Hz, 300 W
 - W x H x D approx. 175 x 280 x 175 mm

Hand mixer
HM 350 CB

- Powerful 250 watt motor
 - 5 speed level
 - Eject button
 - Stainless steel dough hooks and beaters
 - All accessories are dishwasher-safe
- 230 V, 50 Hz, 250 W
 - W x H x D approx. 180 x 280 x 90 mm



Stainless steel insert



Can also be combined as a suitable kitchen set

Art. no. 604 641
EAN 4 004 470 046 410 PU 6



Art. no. 615 681
EAN 4 004 470 156 812 PU 6
Art. no. 615 684
EAN 4 004 470 156 843 PU 6



Art. no. 603 500
EAN 4 004 470 035 001 PU 6





Hand mixer
HM 350 CB

- Powerful 250 watt motor
- 5 speed level
- Eject button
- Stainless steel dough hooks and beaters
- All accessories are dishwasher-safe
- 230 V, 50 Hz, 250 W
- WxHxD approx. 180 x 280 x 90 mm

Hand mixer
CB 334

- Powerful 200 watt motor
- 5 speed level
- Turbo switch
- Eject button
- Kneading hooks and beaters (chromium-plated)
- All accessories are dishwasher-safe
- 230 V, 50/60 Hz, 200 W
- WxHxD approx. 200 x 260 x 80 mm



Can also be combined as a suitable kitchen set

- Art. no. 603 502
EAN 4 004 470 035 025 PU 6
- Art. no. 603 506
EAN 4 004 470 035 063 PU 6
- Art. no. 603 508
EAN 4 004 470 035 087 PU 6

- Art. no. 603 340
EAN 4 004 470 033 403 PU 12





2in1

Hand mixer set
HM 381 CB

- Powerful 300 watt motor
- 5 speed level
- Turbo setting
- Eject button
- Stainless steel dough hooks and beaters (21 cm) (dishwasher-safe)
- 220-240 V, 50/60 Hz, 300 W
- WxHxD approx. 90 x 145 x 200 mm



2in1

Hand mixer set
CB 336

- Powerful 250 watt motor
- 5 speed level
- Turbo setting
- High-speed blender attachment
- With fine steel knife, stainless steel beaters and dough hooks
- Large mixing bowl with automatic drive
- All accessories dishwasher-safe
- 230 V, 50/60 Hz, 250 W
- WxHxD approx. 300 x 350 x 200 mm



Incl. quick blender



Incl. quick blender

Art. no. 603 810
EAN 4 004 470 038 101

PU 6



Art. no. 603 360
EAN 4 004 470 033 601

PU 2





4.7 litre glass dish



1000 Watt



NEW! Kneading machine
KM 1393 CB

NEW! Kneading machine
KM 1394 CB

- High-performance kneading machine with powerful 1000 watt
 - 8 speed level (0-1-2-3-4-5-6 + pulse function)
 - 5 litre fine steel dish for max. 2.5–3 kg dough preparation
 - Aluminium die-cast stirring hook – also enables the uniform mixing of sizeable quantities of dough
 - Aluminium die-cast dough hook – for heavy doughs, e.g. yeast or bread dough
 - Stainless steel whisk for light sponge cake and fluffy egg whites
 - Special robust gear mechanism
 - Constant power through load-dependent, electronic speed control
 - 35° swivelling multifunction arm
 - Unlocking mechanism for multifunction arm
 - Safety circuit
 - Transparent splash protection lid with refill opening (removable)
 - Particularly easy to operate and clean
 - High stability due to suction feet
 - Quick-action chuck for holding the tools
- 220–240 V, 50/60 Hz, 1000 W
 - WxHxD approx. 356 x 309 x 275 mm

- High-performance kneading machine with 800 watt
 - 8 speed level (0-1-2-3-4-5-6 + pulse function)
 - 4.7 litre glass dish for max. 2.5–3 kg dough preparation
 - Aluminium die-cast stirring hook – also enables the uniform mixing of sizeable quantities of dough
 - Aluminium die-cast dough hook – for heavy doughs, e.g. yeast or bread dough
 - Stainless steel whisk for light sponge cake and fluffy egg whites
 - Special robust gear mechanism
 - Constant power through load-dependent, electronic speed control
 - 35° swivelling multifunction arm
 - Unlocking mechanism for multifunction arm
 - Safety circuit
 - Transparent splash protection lid with refill opening (removable)
 - Particularly easy to operate and clean
 - High stability due to suction feet
 - Quick-action chuck for holding the tools
- 220–240 V, 50/60 Hz, 800 W
 - WxHxD approx. 364 x 312 x 284 mm

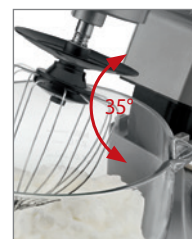

● Art. no. 613 931
EAN 4 004 470 139 310 PU 1
● Art. no. 613 936
EAN 4 004 470 139 365 PU 1

● Art. no. 613 941
EAN 4 004 470 139 419 PU 1





ELECTRONIC

1200 Watt



Kneading machine KM 305 CB

41

- Powerful kneading machine with extra-powerful 1200 watt max.
 - 5 speed level (0-1-2-3-4)
 - 5 LED indicator lights (blue illuminated)
 - 5.6 litre fine steel dish for max. 2.5 kg mixture preparation
 - Stainless steel bowl (rustproof)
 - Aluminium die-cast stirring hook – also enables the uniform mixing of sizeable quantities of dough
 - Aluminium die-cast dough hook – for heavy doughs, e.g. yeast or bread dough
 - Whisk made of stainless steel
 - Special robust gear mechanism
 - Electronic speed control
 - 35° swivelling multifunction arm
 - Unlocking mechanism for multifunction arm
 - Safety circuit (can only be operated with the lid in position or with cover)
 - Transparent splash protection lid
 - Particularly easy to operate and clean
 - High stability due to suction feet
- 220–240 V, 50 Hz, 1200 W max.
 - W x H x D approx. 390 x 350 x 280 mm



Electronic circuit



35° swivelling multifunction arm



Art. no. 603 059
EAN 4 004 470 030 594

PU 1

Art. no. 603 054
EAN 4 004 470 030 549

PU 1

Art. no. 603 056
EAN 4 004 470 030 563

PU 1





1200 Watt

6.3 litre

35° swivelling
multifunction arm



42

NEW! Kneading machine
KM 398 CB

- High-performance kneading machine with extra-powerful 1200 watt
 - 8 speed level (0-1-2-3-4-5-6 + pulse function)
 - 6.3 litre fine steel dish for max. 3-4 kg mixture preparation
 - Aluminium die-cast stirring hook (non-stick coated) – also enables the uniform mixing of sizeable quantities of dough
 - Aluminium die-cast dough hook (non-stick coated) – for heavy doughs, e.g. yeast or bread dough
 - Stainless steel whisk for light sponge cake and fluffy egg whites
 - Special robust gear mechanism
 - 35° swivelling multifunction arm with unlocking mechanism
 - Safety circuit
 - Transparent splash protection lid with refill opening (removable)
 - Particularly easy to operate and clean
 - High stability due to suction feet
 - Quick-action chuck for holding the tools
- 220-240 V, 50 Hz, 1200 W
 - WxHxD approx. 402 x 326 x 212 mm



● Art. no. 603 980
EAN 4 004 470 039 801

PU 1

● Art. no. 603 984
EAN 4 004 470 039 849

PU 1

● Art. no. 603 986
EAN 4 004 470 039 863

PU 1



Incl. glass mixing container with scale and refill opening (1.5 litre capacity)

XXL
fine steel dish
(6.3 litre)



35° swivelling
multifunction
arm

1200 Watt

6.3 litre

NEW! Kneading machine
KM 399 CB

43

- High-performance kneading machine with extra-powerful 1200 watt
 - 8 speed level (0/1/2/3/4/5/6 + pulse function)
 - 6.3 litre stainless steel dish for max. 3–3.5 kg dough preparation
 - Glass mixing container with scale and refill opening (1.5 litre capacity)
 - Aluminium die-cast stirring hook – also enables the uniform mixing of sizeable quantities of dough
 - Aluminium die-cast dough hook – for heavy doughs, e.g. yeast or bread dough
 - Stainless steel whisk for light sponge cake and fluffy egg whites
 - Special robust gear mechanism
 - 35° swivelling multifunction arm with unlocking mechanism
 - Safety circuit
 - Transparent splash protection lid with refill opening (removable)
 - Particularly easy to operate and clean
 - High stability due to suction feet
 - Quick-action chuck for holding the tools
- 220–240 V, 50 Hz, 1200 W
■ W x H x D approx. 428 x 556 x 235 mm





Incl. glass mixing container with scale and refill opening (1.5 litre capacity)

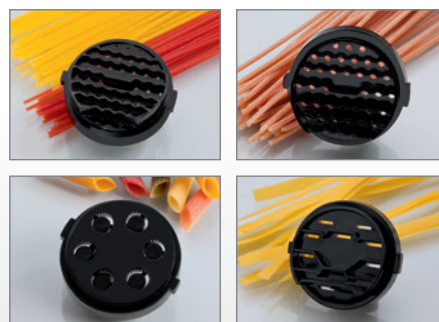

Pasta attachments, e.g. for spaghetti, macaroni, penne and tagliatelle



4in1

1000 Watt

NEW! Kneading machine
KM 1373 CB

- High-performance kneading machine with powerful 1000 watt
- 8 speed level (0/1/2/3/4/5/6 + pulse function)
- 5 litre fine steel dish for max. 2.5–3 kg dough preparation
- Glass mixing container with scale and refill opening (1.5 litre capacity)
- Aluminium die-cast stirring hook – also enables the uniform mixing of sizeable quantities of dough
- Aluminium die-cast dough hook – for heavy doughs, e.g. yeast or bread dough
- Stainless steel whisk for light sponge cake and fluffy egg whites
- Special robust gear mechanism
- 35° swivelling multifunction arm with unlocking mechanism
- Transparent splash protection lid with refill opening (removable)
- Safety circuit
- Particularly easy to operate and clean
- High stability due to suction feet
- Quick-action chuck for holding the tools

Mincer

- Metal tube, metal cutter, 3 steel mincing disks, stainless steel cutter, sausage filler accessory, biscuit attachment, metal refill tray, attachment for oriental dumplings

Pasta function

- Make pasta yourself with 4 different attachments, e.g. spaghetti, penne, macaroni, tagliatelle

- 220–240 V, 50/60 Hz, 1000 W
- WxHxD approx. 426 x 563 x 230 mm



Accessories: 4 different pasta attachments, metal cutter, metal tube, 3 stainless steel mincing disks, biscuit attachment, sausage filler accessory, kebbe attachment for oriental cuisine



Incl. mincer and pasta function



Glass mixing container with scale and refill opening

Art. no. 613 731
EAN 4 004 470 137 316

PU 1





7in1



5in1

Stainless steel

NEW! Food processor
KM 1390 CB

NEW! Food processor
KM 1382 CB

- Powerful food processor with 600 watt
- 4 speed level (0-1-2 + pulse function)
- Mixing vessel with scale and refill opening (1.5 litre capacity)
- Working container with scale and refill opening (1.5 litre capacity)
- Cover for the refill opening can also be used as a measuring beaker (3 cl)
- High-grade, interchangeable attachments from stainless steel for chopping and cutting
- Safety circuit
- Accessories (7in1): Mixing vessel with scale and refill opening (1.5 litre capacity), 1x cutting insert, 1x grating insert, 1x chipping/julienne disc, mixing blade, chopping blade, citrus juicer application, measuring cup (3 cl)
- High stability due to suction feet
- 220–240 V, 50/60 Hz, 600 W
- W x H x D approx. 267 x 385 x 205 mm

- Stainless steel housing
- 4 speed level (0-1-2 + pulse function)
- Mixing vessel with scale and refill opening (1.5 litre capacity)
- Working container with scale and refill opening (1.0 litre capacity)
- Cover for the refill opening can also be used as a measuring beaker (3 cl)
- High-grade, interchangeable attachments from stainless steel for cutting and grating
- Safety circuit
- Accessories (5in1): Mixing vessel with scale and refill opening (1.5 litre capacity), stainless steel cutting/grating insert, mixing blade, chopping blade, measuring cup (3 cl)
- High stability due to suction feet
- 220–240 V, 50 Hz, 500 W
- W x H x D approx. 190 x 370 x 190 mm



Accessories: 1x cutting insert, 1x grating insert, 1x chipping/julienne disc, mixing blade, chopping blade, citrus juicer application



Incl. mixing vessel with scale and refill opening (1.5 litre capacity)



Accessories: 1x stainless steel cutting/grating insert, mixing blade, chopping blade



Incl. mixing vessel with scale and refill opening (1.5 litre capacity)

Art. no. 613 901
EAN 4 004 470 139 013 PU 2



Art. no. 613 821
EAN 4 004 470 138 214 PU 2





1200 Watt

Mincer FW 447 CB

- Chrome-plated front plate
- Metal neck
- Metal feed tray
- Metal feed screw
- 3 stainless steel discs (7/5/3 mm)
- Stainless steel knife
- Reverse function
- Cookie maker attachment
- Sausage filler accessory
- Kebbe attachment – oriental cuisine
- On/off switch
- High stability due to suction feet
- 220–240 V, 50/60 Hz, 1200 W max.
- W x H x D approx. 330 x 355 x 170 mm

| | |
|---|---------------|
| ETM TESTMAGAZIN · URTEIL | |
| Bomann FW 447 CB | |
| GUT | 82,5 % |
| Im Test: 13 Fleischwölfe Testurteile: 1x sehr gut, 12x gut www.etm-testmagazin.de | Heft 11/2015 |



Integrated storage compartment for accessories



Incl. 3 stainless steel discs, cookie maker attachment, kebbe attachment, sausage filler accessory



Universal mixer UM 378 CB

- Universal mixer for pureeing, beating, chopping, shaking and mixing
- Ideal for preparing fruit and fitness drinks, milk shakes, cocktails, soups, salsa sauces, baby food
- Ideal for kitchen and bar
- Ice crush function
- Powerful max. 500 watt motor
- 5 speed level (0-1-2-3-4 + pulse/turbo function)
- Removable mixing bowl (1.5 litre capacity)
- Lid with refill opening
- Cover for the refill opening can also be used as a measuring beaker (2 cl)
- Stainless steel blade (rustproof)
- Safety circuit – operation only possible with vessel in place
- High stability due to rubberized feet
- 220–240 V, 50/60 Hz, 500 W max.
- W x H x D approx. 160 x 400 x 160 mm

Art. no. 604 471
EAN 4 004 470 044 713 PU 4



Art. no. 603 780
EAN 4 004 470 037 807 PU 4





2in1

2in1

Stainless steel

Universal mixer UM 1569 CB

- Universal mixer for pureeing, beating, chopping, shaking and mixing
 - Ideal for preparing fruit and fitness drinks, milk shakes, cocktails, soups, salsa sauces, baby food
 - Ideal for kitchen and bar
 - Stainless steel front
 - Ice crush function
 - Powerful 600 watt motor
 - 4 level switch (0-1-2 + pulse/turbo function)
 - Removable mixing bowl made of solid glass with scale (1.5 litre capacity)
 - Lid with refill opening
 - Cover for the refill opening can also be used as a measuring beaker (5 cl)
 - 4-fold stainless steel blade (rustproof)
 - Safety circuit – operation only possible with vessel in place
 - Knife block removable for cleaning
 - High stability due to rubberized feet
- 220–240 V, 50/60 Hz, 600 W
 - W x H x D approx. 185 x 410 x 200 mm

Universal mixer UM 1354 CB

- Stainless steel universal mixer for pureeing, beating, chopping up, shaking and mixing
- Ideal for preparing fruit and fitness drinks, milk shakes, cocktails, soups, salsa sauces, baby food
- Ideal for kitchen and bar
- Stainless steel housing
- Ice crush function
- Powerful max. 650 watt motor
- 4 speed level (0-1-2 + pulse function)
- Rotary switch (blue illuminated)
- Removable mixing vessel made of solid glass with 1.5 litre capacity (with scale)
- Lid with refill opening
- Cover for the refill opening can also be used as a measuring beaker (2 cl)
- 6-fold stainless steel blade (rustproof)
- Safety circuit – operation only possible with vessel in place
- All accessories are dishwasher-resistant
- Knife block removable for cleaning
- High stability due to rubberized feet
- Cable storage compartment in the base section

- 220–240 V, 50/60 Hz, 650 W max.
- W x H x D approx. 200 x 410 x 185 mm



Can also be combined as a suitable kitchen set

Art. no. 615 691
EAN 4 004 470 156 911 PU 4
Art. no. 615 694
EAN 4 004 470 156 942 PU 4



Art. no. 613 541
EAN 4 004 470 135 411 PU 4





Stainless steel



Mixing cup also suitable as drinking cup

48

NEW! Universal mixer
UM 1374 CB

- Stainless steel universal mixer for pureeing, beating, chopping up, shaking and mixing
 - Ideal for preparing fruit and fitness drinks, milk shakes, cocktails, soups, salsa sauces, baby food
 - Ideal for kitchen and bar
 - Stainless steel housing
 - Ice crush function
 - Powerful 650 watt motor
 - 4 speed level (0-1-2-3-4 + pulse function)
 - Removable mixing vessel made of solid glass with 1.5 litre capacity (with scale)
 - Lid with refill opening
 - Cover for the refill opening can also be used as a measuring beaker (6.5 cl)
 - 4-fold stainless steel blade with „piranha“ cut for easy mixing (rustproof)
 - Safety circuit – operation only possible with vessel in place
 - High stability due to rubberized feet
- 220–240 V, 50/60 Hz, 650 W
■ W x H x D approx. 177 x 400 x 175 mm

Smoothie maker
SM 386 CB

- Universal mixer for pureeing, beating, chopping up, shaking and mixing, consisting of base, mixing cup and lid with drinking aperture
 - “Mix & Go” – Mix your favorite shake in a few minutes. With the practical drinking aperture, you can take your freshly prepared shake with you to work, school or sports
 - Ideal for preparing fruit and fitness drinks, milk shakes, cocktails, soups, salsa sauces, baby food
 - Incl. recipe suggestions
 - Incl. lid with drinking aperture
 - Ideal for kitchen, bar and on the road
 - Powerful motor, 250 W
 - 1 speed (pulse function)
 - Detachable mixing container (600 ml)
 - Stainless steel blade (rustproof)
 - Safety circuit – operation only possible with vessel in place
 - All accessories dishwasher safe
 - High stability due to rubberized suction pads
- 220–240 V, 50 Hz, 250 W
■ W x H x D approx. 130 x 370 x 125 mm

Replacement bottle for
Smoothie maker



Art. no. 264 559
EAN 4 006 160 645 590

VE 6



Art. no. 613 741
EAN 4 004 470 137 415 PU 4



- Art. no. 603 862
EAN 4 004 470 038 620 PU 6
- Art. no. 603 866
EAN 4 004 470 038 668 PU 6
- Art. no. 603 868
EAN 4 004 470 038 682 PU 6



Citrus fruit squeezer
ZP 1092 CB

- Removable bowl with aroma protective cover (1.2 litre)
- 2 press cones
- Automatic start/stop function by pressing juicer cone
- Automatic clockwise/anticlockwise operation for optimal juice extraction
- Practical cable tidy
- 230 V, 50 Hz, 40 W
- WxHxD approx. 180 x 230 x 180 mm



Automatic juicer
AE 1028 CB

- Powerful 400 watt max.
- Fresh fruit and vegetable juices quickly prepared. Rich in vital substances for well-being, fitness and health
- 30% more juice and vitamins
- Removable pulp container
- Removable juice container
- On/off switch
- Lock with safety switch
- Stainless steel micro-strainer for finest juices
- Can be completely taken apart for rapid and unproblematic cleaning
- Safe stand
- 220–240 V, 50 Hz, 350–400 W max.
- WxHxD approx. 235 x 330 x 210 mm



Stainless steel



Stainless steel

Professional automatic juicer AE 1917 CB

- Professional automatic juicer in high-quality stainless steel housing
- Fresh fruit and vegetable juices quickly prepared. Rich in vital substances for well-being, fitness and health
- 30 % more juice and vitamins
- Extra large filler spout (75 mm Ø)
- Extracts the juice from apples, carrots and other fruits within seconds without having to chop them
- Powerful 1000 watt motor max.
- 3 speed levels (0-1-2) for different fruit hardness
- High volume pulp container (approx. 2.0 litre capacity)
- Open stainless steel juice spout
- Drip-stop – no splashes and no wiping
- Lock with safety switch
- Stainless steel sieve for finest juices
- Can be completely disassembled – quick and easy cleaning
- High stability
- 230 V, 50 Hz, 1000 W max.
- W x H x D approx. 300 x 400 x 220 mm



Extra large filler spout
(75 mm Ø)



Drip-stop – no splashes and
no wiping

NEW! Automatic juicer AE 1918 CB

- Professional automatic juicer in high-quality stainless steel housing
- Fresh fruit and vegetable juices quickly prepared. Rich in vital substances for well-being, fitness and health
- 30 % more juice and vitamins
- Large filler spout (65 mm Ø)
- 3 speed levels (0-1-2) for different fruit hardness
- Pulp container (approx. 1.5 litre capacity)
- Open juice spout
- Drip-stop due to a folding juice spout
- Lock with safety switch
- Stainless steel sieve for finest juices
- Can be completely disassembled – quick and easy cleaning
- High stability
- 220–240 V, 50/60 Hz, 400 W max.
- W x H x D approx. 272 x 295 x 171 mm



Large filler spout
(65 mm Ø)



Drip-stop due to a
folding juice spout

Art. no. 619 171
EAN 4 004 470 191 714

PU 2



Art. no. 619 181
EAN 4 004 470 191 813

PU 4





Stainless steel

Glass kitchen scale
KW 1515 CB

Kitchen scale
KW 1421 CB

Food dryer
DR 448 CB

- Extra-flat digital kitchen scale
- Weighing surface made of high-quality glass
- Clearly legible LCD display
- Weights up to 5 kg (1 g scaling)
- Adjustable measuring units: g, lb-oz, ml, fl-oz
- Automatic switch-off
- On/off switch
- Tare function (additive weighed function)
- High stability due to rubberized feet
- Low battery indication
- Battery-operated: 1 x CR 2032 (battery supplied)
- W x H x D approx. 150 x 17 x 220 mm

- Extra-flat digital kitchen scales with permanent clock and temperature information
- Stainless steel weighing surface
- Clearly legible, high-quality multifunction LCD display
- Weights up to 5 kg (1 g scaling)
- Adjustable measuring units: kg, g, lb, oz
- Automatic switch-off for weighing function
- On/off switch
- Tare function (additive weighed function)
- Battery-operated: 3 x AAA (batteries supplied)
- W x H x D approx. 160 x 18 x 230 mm

- Foot dryer dries fruit, vegetables, herbs, meat etc. Rich in essential minerals for well-being, fitness and health
- 2 temperature stages
- Variable use by 5 large, transparent, and stackable level (easy cleaning)
- Circulation fan, air circulation function
- Overheating protection
- 220-240 V, 50 Hz, 300 W
- W x H x D approx. 330 x 315 x 327 mm



Can also be combined as a suitable kitchen set



Variable use by 5 large, transparent, and stackable levels (easy cleaning)

- Art. no. 615 151 PU 6
EAN 4 004 470 637 304
- Art. no. 615 155 PU 6
EAN 4 004 470 151 558
- Art. no. 615 156 PU 6
EAN 4 004 470 151 565
- Art. no. 615 157 PU 6
EAN 4 004 470 151 572

- Art. no. 614 211 PU 6
EAN 4 004 470 142 112

- Art. no. 604 480 PU 4
EAN 4 004 470 616 996





52

Bag sealer FS 1014 CB

- Ideal for dividing food into portions
- Electronically controlled bag sealer
- Seals and separates in one operation
- Strong extraction pump
- With bag storage view window
- 2 indicator lights
- Cord storage in base
- Incl. a roll of film (3 m)

- 220–240 V, 50/60 Hz, 100 W
- W x H x D approx. 330 x 80 x 125 mm

Spare rolls:

Art. no. 8900216
EAN 4 006 160 900 217 PU 10



Fondue deep fat pan FFR 1290 CB

- Cool touch housing
- Capacity: 1 litre oil/frying fat
- Deep frying basket with removable handle
- Continuously variable thermostat
- Control panel with display
- 6 fondue forks marked in colour
- Protective ring against spray/fork holder
- Changeable odour and fumes filter
- Overheating protection

- 220–240 V, 50 Hz, 840 W
- W x H x D approx. 190 x 240 x 190 mm



Deep fat fryer FR 2223 CB

- Cool touch housing
- Capacity: approx. 2 litre oil/frying fat
- Oil container with non-stick coating
- Large frying basket, can be raised and lowered with the lid closed
- Pop-up lid with viewing window (detachable)
- On/off switch (0-1)
- Continuously adjustable thermostat with indicator light (130°C–190°C)
- 2 indicator lights for power and heating
- Changeable odour and fumes filter
- Collecting container for condensation
- 2 recessed grips for safe transport

- 230 V, 50 Hz, 1800 W
- W x H x D approx. 245 x 260 x 320 mm



Art. no. 610 140
EAN 4 004 470 101 409 PU 6



Art. no. 612 900
EAN 4 004 470 129 007 PU 4



Art. no. 622 230
EAN 4 004 470 222 302 PU 2





Removable
oil container



Deep fat fryer FR 2287 CB

- Cool touch housing
- Capacity: 3 litre of oil/frying fat
- Removable oil container (non-stick coated)
- Large frying basket (can be raised or lowered with the lid closed)
- Pop-up lid with viewing window
- Continuously adjustable thermostat (130°C–190°C)
- 30 minute timer with shut-off signal
- 2 indicator lights for temperature/operation
- Changeable odour and fumes filter
- Cable rewind
- 230 V, 50 Hz, 2000 W
- W x H x D approx. 260 x 260 x 420 mm

NEW! Deep fat fryer FR 2253 CB

- Stainless steel applications
- Capacity: 2.5 litre of oil/frying fat
- Oil container (non-stick coated)
- Pop-up lid with viewing window (removable)
- Continuously adjustable thermostat (130°C–190°C)
- 2 indicator lights for temperature/operation
- Odour and fumes filter
- Drip tray
- Carrying handles (heat-insulated)
- Overheating protection
- 230 V, 50 Hz, 1600 W
- W x H x D approx. 310 x 230 x 310 mm



 **Stainless steel**



54

Stainless steel deep fat fryer
FR 2264 CB

NEW! **Hot air fryer**
FR 2301 H CB

- Housing, lid, heating coil made of stainless steel
 - Cool zone technology – heating coils immersed directly in the oil for rapid heating and for odorless frying
 - Capacity: 3 litre of oil/frying fat
 - Continuously adjustable thermostat with indicator light
 - Removable fat container (enamelled)
 - Stainless steel heating coil (removable)
 - Drip tray
 - Carrying handles (heat-insulated)
 - Cord storage
 - Overheating protection
- 230 V, 50 Hz, 2000 W
■ W x H x D approx. 215 x 240 x 405 mm

- Oil and fat free hot air fryer
 - Low smoke or odors
 - Time and energy-saving cooking
 - Cool touch handle
 - Stainless steel inserts
 - Capacity: 2.2 litre
 - Removable container (non-stick coated) with safety switch
 - Continuously adjustable thermostat (80°C–200°C)
 - 60 minute timer with shut-off signal
 - 2 indicator lights for temperature/operation
 - Overheating protection
- 220–240 V, 50/60 Hz, 1500 W
■ W x H x D approx. 265 x 335 x 315 mm

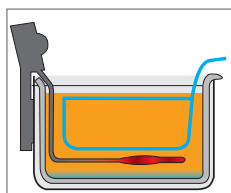

Capacity: 2.2 litre

● **Art. no. 622 641**
EAN 4 004 470 226 416 PU 2



● **Art. no. 623 019**
EAN 4 004 470 230 116 PU 2





2in1



Stainless steel



Jam/marmelade program



Wholemeal program



Jam/marmelade program



Wholemeal program

Rice cooker
RK 2282 CB

Bread maker
CB 594

Bread maker
BBA 566 CB

- Rice cooker and steam cooker in one
- Rice cooker for easy preparation and keeping warm all types of rice, pulses, soups, cereals
- Stainless steel housing
- Additional aluminium steamer insert for vitaminretaining steam cooking of e.g. vegetables, potatoes and fish
- Safety glass lid with steam outlet
- Removable pot (non-stick coating)
- For max. 1300 g of rice (uncooked weight) yields approximately 2500 g cooked rice
- Automatic keep warm mode when cooking has finished
- Automatic switch-off (energy-saving)
- On/off switch
- Cool touch handles
- Removable supply cable
- Safety function: can only be switched on when pot is in position
- 3 indicator lights for cooking, keeping warm and mains
- Accessories: measuring beaker (160 ml max.), rice spoon
- 220–240 V, 50/60 Hz, 700 W
- W x H x D approx. 310 x 310 x 260 mm



Incl. aluminium steamer insert

- Fully automatic dough and bread preparation (kneading, rising, baking)
- Non-stick coated baking form (removable)
- 3 litre capacity (corresponds to about 1300 g bread)
- 9 baking programs / 31 available settings
- Programs: Normal, french, whole wheat, sweet, dough, cake, sandwich, baking, fast baking
- Marmalade program
- Warming function
- Electronic control panel with LCD display and audible signal
- 13 hour timer
- Variably settable dough quantity
- Variable crust browning control (light, medium, dark)
- Cool touch housing
- Lid with viewing window
- 2 kneading pegs
- Accessories: measuring beaker and spoon
- 230 V, 50 Hz, 800 W
- W x H x D approx. 400 x 290 x 260 mm

- Fully automatic dough and bread preparation (kneading, rising, baking)
- Non-stick coated baking form (removable)
- 2 litre capacity (corresponds to about 1000 g bread)
- 12 baking programs / 39 available settings
- Programs: Normal, french, whole wheat, fast baking, sweet, ultra fast baking I, ultra fast baking II, dough, jam, cake, sandwich, baking
- Marmalade program
- Extra bake function
- Warming function
- Electronic control panel with backlight LCD display
- 13 hour timer
- Variably settable dough quantity
- Variable crust browning control (light, medium, dark)
- Cool touch housing
- Lid with viewing window (removable)
- 230 V, 50 Hz, 600 W
- W x H x D approx. 405 x 305 x 265 mm

Art. no. 622 821
EAN 4 004 470 228 212

PU 2



Art. no. 605 940
EAN 4 004 470 059 403

PU 2



Art. no. 605 660
EAN 4 004 470 056 600

PU 2





2in1 Hot dog maker & egg boiler

56

Steam cooker
DG 1218 CB

- Steam cooker for the healthy cooking of food without burning vitamins
- 3 steam cooker containers (1 lid, 1 rise bowl)
- Semi-transparent water tank (1.6 litre)
- Drip bowl for the collection of juices
- 60 minute timer
- Water replenishable during operation
- Water level indicator
- Easy to clean
- Overheating protection
- 220–240 V, 50 Hz, 650–750 W
- W x H x D approx. 300 x 420 x 210 mm

Steam cooker
DG 2286 CB

- Steam cooker for the healthy cooking of food without burning vitamins
- Water-inflow-control – faster steam generation
- 3 steam cooker containers, 1 lid, 1 rise bowl
- High-grade steel base
- Programmable digital timer
- Incl. LCD display (blue illuminated)
- Incl. power control light
- Drip pan for collecting liquids
- Water level indicator
- Add more water during operation
- Easy to clean
- Overheating protection
- 220–240 V, 50/60 Hz, 700–800 W
- W x H x D approx. 310 x 445 x 240 mm

Hot dog maker
HDM 462 EK N CB

- Hot dog maker and egg boiler in one
- For 1 to 14 small sausages (e.g. “Frankfurter”, “Vienna sausages”)
- Heated stainless steel skewer
- Preparation of up to 6 eggs
- Removable egg holder
- Transparent steam tank (removable)
- Non-stick coated water bowl
- 2 separate switches for spike and steamer (blue illuminated)
- Incl. measuring cup with egg pricker
- 230 V, 50 Hz, 380 W
- W x H x D approx. 235 x 270 x 160 mm



High-grade steel base incl. LCD display / timer with backlight



Art. no. 612 185
EAN 4 004 470 121 858 PU 4



Art. no. 622 861
EAN 4 004 470 228 618 PU 2



Art. no. 604 620
EAN 4 004 470 046 205 PU 6





Stainless steel



Stainless steel

Ceramic coated

Contact grill
KG 2242 CB

- Contact grill for double-sided, fat-free grilling
 - Fat drainage channel and drip tray (tray removable for easy cleaning)
 - 2000 watts
 - Stainless steel housing
 - Continuously adjustable thermostat
 - Short cooking times
 - Non-stick grill plates with extra deep grooves for strong grill pattern and smooth fat drainage
 - Large, heat-insulated handle
 - 2 indicator lights for power supply and heating
 - Temperature "ready" display
 - Large grill area: approx. 29.5 x 23.5 cm
 - Cord storage
 - Versatile, can be used for e.g. panini, steaks, fish or vegetables
- 220–240 V, 50/60 Hz, 2000 W
 - W x H x D approx. 335 x 145 x 335 mm

Contact grill
KG 2284 CB

- Contact grill for double-sided, fat-free grilling
 - Barbecue grill – 180° opening enables grilling on a large surface
 - Fat drainage channel and drip tray (tray removable for easy cleaning)
 - 2000 watt
 - Stainless steel housing
 - Continuously adjustable thermostat
 - Short cooking times
 - Scratch-resistant, ceramic coated grill plates with extra deep grooves for strong grill pattern and optimal fat runoff
 - Large, heat-insulated handle
 - 2 indicator lights for power supply and heating
 - Temperature "ready" display
 - Large grill areas: 2x approx. 29.5 x 23.5 cm
 - Cord storage
 - Versatile, can be used for e.g. panini, steaks, fish or vegetables
- 220–240 V, 50/60 Hz, 2000 W
 - W x H x D approx. 356 x 145 x 336 mm



Stainless steel housing



Scratch resistant ceramic coating



Stainless steel housing



Barbecue grill – 180° opening enables grilling on a large surface

Art. no. 622 421
EAN 4 004 470 224 214

PU 3



Art. no. 622 840
EAN 4 004 470 228 403

PU 3





Ceramic coated



58

Party pan
PP 2233 C CB

- Party pan for cooking, roasting, steaming, defrosting and with keep warm function
- Quick heating and long keep warm function
- Removable supply line with continuously adjustable thermostat
- Ceramic coated pan (scratch-proof and easy to clean)
- Ø 32 cm, depth: 3.5 cm
- Heat-resistant glass lid with handle
- Heat-insulated carrying handle

- 220–240 V, 50/60 Hz, 1500 W
- WxHxD approx. 380 x 160 x 400 mm

Party pan
PP 1291 CB

- Party pan for cooking, roasting, steaming, defrosting and with keep warm function
- Quick heating and long keep warm function
- Removable supply line with continuously adjustable thermostat
- Non-stick coated pan (easy to clean)
- Ø 38 cm, depth: 4 cm
- Heat-resistant glass lid with handle
- Heat-insulated carrying handles

- 220–240 V, 50 Hz, 1400 W
- WxHxD approx. 450 x 140 x 400 mm



Scratch resistant ceramic coating

● Art. no. 622 332
EAN 4 004 470 223 323 PU 2



● Art. no. 612 910
EAN 4 004 470 129 106 PU 2





Ceramic coated



Party pan PP 2283 C CB

- Party pan for cooking, roasting, steaming, defrosting and with keep warm function
- Quick heating and long keep warm function
- Removable supply line with continuously adjustable thermostat
- Ceramic coated pan (scratch-proof and easy to clean)
- Ø 42 cm, depth: 9 cm
- Heat-resistant glass lid with handle
- Heat-insulated carrying handles
- 220–240 V, 50/60 Hz, 1500 W
- WxHxD approx. 430 x 145 x 490 mm

Raclette grill RG 2247 CB

- Cool touch housing
- For grilling and browning
- Removable grill plate
- 8 pans
- 8 wooden spatulas
- Continuously adjustable thermostat
- Indicator light
- Non-stick coating on the grill plates and pans (easy to clean)
- Grill area: approx. 40.5 x 30 cm
- Safe base due to rubberized feet
- 220–240 V, 50/60 Hz, 1200–1400 W
- WxHxD ca. 430 x 130 x 340 mm

59



Scratch resistant ceramic coating



8 wooden spatulas

Art. no. 622 832
EAN 4 004 470 228 328

PU 2



Art. no. 622 471
EAN 4 004 470 224 719

PU 3





2 in 1 Raclette grill
RG 2279 CB

Barbecue standing grill
BQS 2244 CB

- Cool touch housing
- For grilling and browning
- Turning iron plate – Combination grill area for grilling fish (smooth surface) or meat (extra deep grooves for an intense grill pattern)
- Natural grill stone for a healthy, low-fat grilling
- Total grill area: ca. 46 x 23 cm (2x ca. 23 x 23 cm)
- 8 pans, 8 wooden spatula
- Continuously adjustable thermostat (blue illuminated)
- Non-stick coating on the grill plates and pans (easy to clean)
- 220–240 V, 50/60 Hz, 1200–1400 W
- W x H x D approx. 465 x 150 x 235 mm

- Stand grill in an attractive design with low smoke emission and low smell
- Continuously adjustable thermostat with indicator light
- Chromed grill grid
- Removable grill and heating elements for easy cleaning
- Cool touch housing
- Metal drip tray
- Wind protection (removable)
- Additional tray
- Can be converted to a table grill
- Grill height: approx. 80 cm
- Grilling surface: 35.5 x 24.5 cm
- 230 V, 50 Hz, 2000 W
- W x H x D approx. 510 x 820 x 370 mm



Natural grill stone for a healthy, low-fat grilling



Continuously adjustable thermostat (illuminated in blue)



Combination grill area for grilling fish or meat (turning iron plate)



● Art. no. 622 791
EAN 4 004 470 227 918 PU 2



● Art. no. 622 441
EAN 4 004 470 224 412 PU 4





Barbecue table grill BQ 2243 CB

- Table grill in an attractive design with low smoke emission and low smell
- Continuously adjustable thermostat with indicator light
- Chromed grill grid
- Removable grill and heating elements for easy cleaning
- Cool touch housing
- Metal drip tray
- Wind protection
- Grilling surface: 36 x 25 cm
- 230 V, 50 Hz, 2000 W
- WxHxD approx. 510 x 145 x 370 mm

Barbecue table grill BQ 1240 N CB

- Table grill in an attractive design without fire and smoke
- Cool touch housing
- On/off switch with indicator lamp
- Removable grill and heating elements for easy cleaning
- Metal drip tray
- Grilling surface: 35.5 x 24.5 cm
- 230 V, 50 Hz, 2000 W
- WxHxD approx. 480 x 100 x 360 mm



Gas grill
GG 2262 CB



NEW! **Vertical Doner Multigrill**
DVG 2410 CB

- 2x heating zones for separate temperature control (2 Burner)
- Sturdy grill hood with integrated temperature display
- Control knobs for continuous temperature setting
- 48,5 x 37,5 cm grill area comprising of one enameled grill rack (dishwasher safe)
- 48,5 cm long warming rack (enameled)
- Removable grease collection tray for easy cleaning
- 2 x burners
- Housing and side trays made of powder-coated steel
- Two wheels for convenient movement
- Convenient storage basket for different grilling utensils
- Large storage room / Storage for gas bottle
- Incl. gas pressure reduction valve and gas tube for Germany and Austria

Specifications

- Burners: 2
- Main burner: 2x 2,75 kW / 5,5 kW
- Gas consumption: 400 gr/h
- Operating pressure: 50 mbar
- Ignition: Piezo ignition system
- Gas category: 13B/P(50)
- Gas type: Butane, propane, or their mixtures
- Target destinations: D, A, CH
- CE certification: Intertek institute, certification number: 0359BU1034
- W x H x D approx. 970 x 1000 x 550 mm



Integrated temperature display



Convenient storage basket for different grilling utensils



Grill rack and warming rack (enameled)

- Vertical Doner Multigrill for fat-free grilling of chickens, kebab/gyros or meat skewers
- Thanks to its vertical position, escaping jus drips directly into the stainless steel fat tray
- Internal lighting
- Cooking chamber: approx. 21 litre
- Incl. 1 rotary spit for chickens or kebab/gyros
- Incl. 7 meat skewers
- 60 minute timer with end signal
- 2 temperature settings (750/1500 W)
- Indicator light
- 220–240 V, 50/60 Hz, 1500 W
- W x H x D approx. 282 x 446 x 334 mm



1 rotary spit for chickens or kebab/gyros



7 meat skewers

Art. no. 622 621
EAN 4 004 470 226 218

PU 1

CE 0359

Art. no. 624 101
EAN 4 004 470 241 013

PU 1

CE



Convection oven HLO 2280 CB

- Gentle cooking by circulating hot air, low-fat and vitamin-preserving
 - Many different uses for baking, roasting, grilling, steaming, braising, defrosting, heating, barbecuing (easy to use)
 - Halogen heating element for faster heating
 - Saves time and energy: requires up to 45 % less energy than a conventional oven
 - Ideal for small kitchens and mobile use
 - Continuously adjustable thermostat from 0–200 °C
 - 12 litre interior
 - Glass bowl: Ø 33 cm
 - Container made of safety glass – heat and scratch-resistant (dishwasher-safe)
 - 60 minute timer with alarm when cooking is completed
 - Indicator lights for operation and temperature
 - Safety switch, practical safety handle
 - Heat-insulated carrying handles
 - Accessories: upper and lower grid, steamer insert, tongs, skewers, lid holder
- 220–240 V, 50/60 Hz, 1200–1400 W
 - WxHxD approx. 380 x 335 x 355 mm

Mini oven MB 2245 CB

- 8 litre capacity
 - Top and bottom heat
 - 15 minute timer
 - 2 quartz heating elements
 - Pull-out grill grid
 - Baking tray
 - Drawer for crumbs
 - Overheating protection
- 220–240 V, 50/60 Hz, 800 W
 - WxHxD approx. 365 x 220 x 250 mm



Lower/upper grid



Steamer insert

Art. no. 622 800
EAN 4 004 470 228 007

PU 1



Art. no. 622 451
EAN 4 004 470 224 511

PU 4





64

Multi pizza oven MPO 2246 CB

- Pizza oven ideal for grilling and crisping up
- Large grill, ideal for pizza (26 x 25 cm)
- Including baking tray (23.5 x 22 cm)
- Capacity: approx. 12 litre
- Top and bottom heat (combined operation possible)
- 4-step switch (top heat, bottom heat, top and bottom heat combined, off)
- 2 quartz heating elements
- 60 minute timer with end signal
- Stainless steel handle
- Crumb tray
- Overheating protection
- 220–240 V, 50/60 Hz, 1000 W
- WxHxD approx. 375 x 220 x 330 mm

Multi oven MBG 2249 CB

- 28 litre capacity
- Circulating air
- Top and bottom heat, combined operation
- Revolving spit
- 60 minute timer with end signal
- 5-step switch (top/bottom/top and bottom heat/revolving spit/off)
- Variable temperature control (100°C–230°C)
- Indicator light
- Includes grill grid, baking tray, revolving spit
- Includes tongs for removing the grill grid and baking tray, tool for removing the revolving spit
- Large viewing window
- 220–240 V, 50/60 Hz, 1500 W
- WxHxD approx. 520 x 335 x 420 mm



Incl. baking tray (23.5 x 22 cm)



Incl. revolving spit

● Art. no. 622 461
EAN 4 004 470 224 610 PU 4



● Art. no. 622 490
EAN 4 004 470 224 900 PU 1





Multi oven MBG 2252 CB

- 28 litre capacity
- Circulating air
- Top and bottom heat, combined operation
- Revolving spit
- 60 minute timer with end signal
- 6 level switch
 - Top and bottom heat
 - Top and bottom heat + circulating air
 - Top heat + circulating air
 - Top heat + revolving spit
 - Top and bottom heat + revolving spit + circulating air
 - Off
- Variable temperature control (100°C–230°C)
- Indicator light
- Includes grill grid, baking tray, revolving spit
- Includes tongs for removing the grill grid and baking tray, tool for removing the revolving spit
- Large viewing window
- 220–240 V, 50/60 Hz, 1500 W
- W x H x D approx. 495 x 380 x 330 mm



Incl. revolving spit

Mini kitchen KK 2250 CB

- 2 hotplates
 - 1x Ø 18.5 cm, 1500 watt
 - 1x Ø 15.5 cm, 1000 watt
- 2 different operating controls for the hotplates:
 - Small – rotary switch level 0–4
 - Large – rotary switch level 0, 850, 1100 and 1500 watt
- 28 litre capacity
- Combined operation (baking and cooking at the same time)
- Top and bottom heat (900/600 watt)
- Possible baking/grilling alternatives:
 - Top and bottom heat
 - Only bottom heat
 - Top heat
- Infinitely adjustable thermostat
- Indicator light
- Oven door with viewing window
- Including grill grating, baking sheet, and crumbs drawer, as well as hookable handle for pulling out the sheet/grating
- Power supply:
 - 600 watt oven (bottom heat), 900 watt oven (top heat)
 - 1000 watt hotplate (small), 1500 watt hotplate (large)
 - 3400 watt (total power consumption)
- 220–240 V, 50 Hz, 3400 W
- W x H x D approx. 518 x 415 x 360 mm



Microwave
MW 2288 CB

- 700 watt microwave
- 20 litre oven capacity
- 6 level
- Rotating plate, Ø approx. 24.5 cm
- 30 minute timer with end signal
- Oven light
- Large viewing window

- 230–240 V, 50 Hz, 1200 W
- W x H x D approx. 455 x 265 x 340 mm

Microwave with grill
MWG 2289 CB

- 700 watt microwave
- 900 watt grill
- 20 litre oven capacity
- 5 microwave power level
- 3 levels in combined operation (grill/microwave)
- 1 grill level
- Rotating plate: Ø approx. 24.5 cm
- Cooking grid: Ø approx. 20.0 cm
- 30 minute timer with end signal
- Oven light
- Large viewing window

- 230–240 V, 50 Hz, 1200 W
- W x H x D approx. 455 x 265 x 340 mm

● Art. no. 622 880
EAN 4 004 470 228 809 PU 1
● Art. no. 622 889
EAN 4 004 470 228 892 PU 1



● Art. no. 622 890
EAN 4 004 470 228 908 PU 1
● Art. no. 622 899
EAN 4 004 470 228 991 PU 1
● Art. no. 622 891
EAN 4 004 470 228 915 PU 1





3in1

Convection

Microwave with grill and convection
MWG 2285 H CB

- Stainless steel front
- 800 watt microwave power
- 1350 watt grill
- 1350 watt convection
- Quick-start function
- 20 litre capacity
- 11 microwave power level
- 2 level in combined operation (grill/microwave)
- 4 level in combined operation (convection/microwave)
- 1 grill level
- 10 temperature settings for convection
- 9 automatic programs incl. defrost program
- Rotating plate, Ø approx. 24.5 cm
- Grilling grid, Ø approx. 20.0 cm
- 95 minute timer with end signal
- Quartz heating elements
- Digital clock
- Child lock
- Oven light

- 230–240 V, 50 Hz, 1200 W
- W x H x D approx. 455 x 262 x 375 mm

3in1

Convection

Stainless steel

Microwave with grill and convection
MWG 2281 H CB

- Stainless steel housing
- Reflecting glass front
- 800 watt microwave
- 1200 watt grill
- 1200 watt convection
- 23 litre capacity
- 5 microwave power level
- 2 level in combined operation (microwave/grill)
- 10 level in combined operation (microwave/convection)
- 1 grill level
- 10 temperature settings for convection
- 10 automatic programs
- 2 defrost programs
- Rotating plate, Ø approx. 27.0 cm
- Grilling grid, Ø approx. 21.0 cm
- 95 minute timer with end signal
- Quartz heating elements
- Digital clock
- Child lock
- Oven light

- 230 V, 50 Hz, 1300 W
- W x H x D approx. 485 x 295 x 405 mm



4in1



Stainless steel

Convection

Stand-alone/
Under-cabinet mounting

Double-grill microwave MWG 2218 H CB

- Stainless steel housing
 - Stainless steel interior
 - Double grill for, for example, crispy pizza, baguettes, soufflés, etc. (1100 watt top heat, 500 watt lower heat)
 - 900 watt microwave
 - 1600 watt double grill
 - 2500 watt convection
 - Quartz top heating element
 - 25 litre capacity
 - 5 microwave power levels
 - 10 temperature settings convection
 - 10 automatic programs
 - Defrost program
 - Quick-start program
 - Incl. pizza program and pizza stone, Ø approx. 30.0 cm
 - Incl. enameled rotating plate, dishwasher-safe and scratchproof, Ø approx. 30.0 cm
 - Grilling grid, Ø approx. 25.0 cm
 - 95 minute timer with end signal
 - Start delay
 - Digital clock
 - Child lock
 - Oven light
- 230 V, 50 Hz, 1500 W
■ W x H x D approx. 510 x 300 x 430 mm



Pizza function incl. pizza stone

Combined microwave oven with grill MWG 2211 U CB

- Stainless steel front
 - 800 watt microwave
 - 1000 watt grill
 - 20 litre capacity
 - 5 microwave power level
 - 2 level in combined operation
 - 1 grill level
 - 8 automatic programs
 - Defrost programs, selectable according to time and weight
 - Quick-start program
 - Rotating plate, Ø approx. 24.5 cm
 - Grilling grid, Ø approx. 21.0 cm
 - 95 minute timer with end signal
 - Easy Tronic, digital clock, child lock
 - Oven light
 - Large viewing window
 - Can be positioned as required or used as a built-under appliance (incl. installation material)
- 230 V, 50 Hz, 1250 W
■ W x H x D approx. 460 x 285 x 370 mm



Built-under appliance

Art. no. 622 181
EAN 4 004 470 221 817

PU 1



Art. no. 622 111
EAN 4 004 470 221 114

PU 1





Built-in microwave with grill
MWG 2215 EB

- Built-in microwave with frame
- Stainless steel front, stainless steel interior
- 800 watt microwave
- 1000 watt grill
- 5 microwave power level
- 2 level in combined operation (grill/microwave)
- 1 grill level
- 8 automatic programs
- Defrost programs, selectable according to time and weight
- 20 litre capacity
- Rotating plate, Ø approx. 24.5 cm, grilling grid, Ø approx. 21 cm
- 95 minute timer with end signal
- Start delay
- Child lock
- Oven light

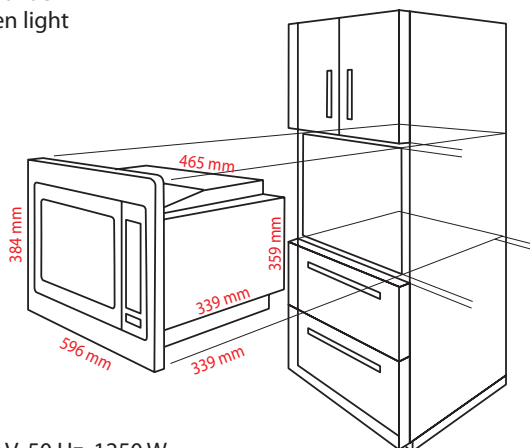

- 230 V, 50 Hz, 1250 W
- Appliance (W x H x D): 465 x 359 x 339 mm
- Appliance with frame (W x H x D): 596 x 384 x 339 mm
- Weight: approx. 14 kg



Built-in microwave with grill and convection
MWG 2216 H EB

- Built-in microwave with frame
- Stainless steel front, stainless steel interior
- 900 watt microwave
- 1100 watt grill
- 2500 watt convection function
- 5 microwave power level
- 2 level in combined operation (grill/microwave)
- 2 level in combined operation (convection/microwave)
- 1 grill level
- 10 temperature settings for convection (130°C–220°C)
- 10 automatic programs
- 2 defrost programs, 1 quick-start program
- 25 litre capacity
- Rotating plate, Ø approx. 32.0 cm, grilling grid, Ø approx. 26.0 cm
- 95 minute timer with end signal
- Start delay
- Child lock
- Oven light

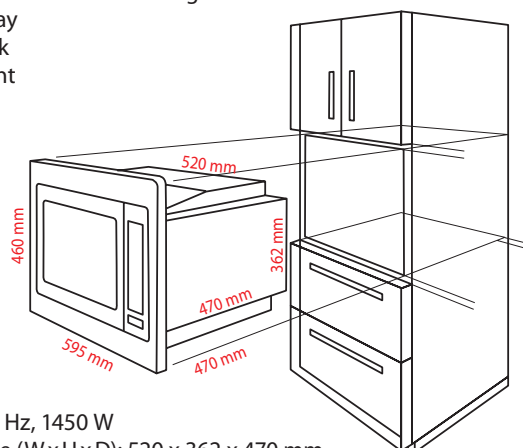

- 230 V, 50 Hz, 1450 W
- Appliance (W x H x D): 520 x 362 x 470 mm
- Appliance with frame (W x H x D): 595 x 460 x 470 mm
- Weight: approx. 21 kg



70

NEW! Built-in microwave with grill
MWG 2267 EB

NEW! Built-in microwave with grill
and convection MWG 2269 H EB

- Built-in microwave oven
- Stainless steel front/interior
- LED display
- Digital clock
- 800 watt microwave
- 1000 watt grill
- 6 microwave power level
- 2 level in combined operation (microwave/grill/convection)
- 1 grill level
- 9 automatic programs
- Defrost program
- Quick-start program
- 20 litre capacity
- Rotating plate, Ø approx. 24.5 cm
- Grill rack, Ø approx. 20.0 cm
- 95 minute timer with end signal
- Child lock
- Oven light

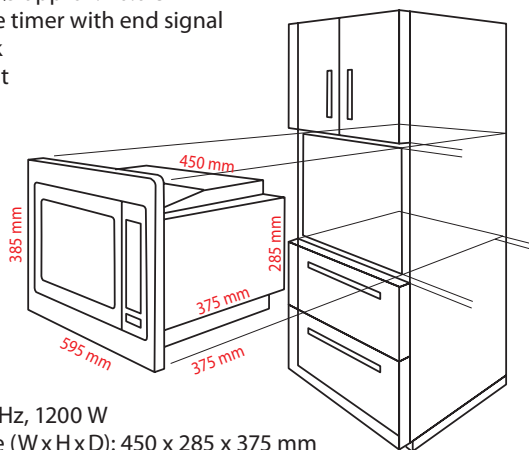

- 230 V, 50 Hz, 1200 W
- Appliance (W x H x D): 450 x 285 x 375 mm
- Appliance with frame (W x H x D): 595 x 385 x 375 mm
- Weight: approx. 14.5 kg

- Built-in microwave oven
- Stainless steel front/interior
- LCD display
- Digital clock
- 900 watt microwave
- 1950 watt grill
- 1950 watt convection
- 6 microwave power levels
- 3 levels in combined operation (microwave/grill/convection)
- 1 grill level
- 10 temperature settings for convection (110°C–200°C)
- 13 automatic programs
- Defrost program
- Quick-start program
- 25 litre capacity
- Rotating plate, Ø approx. 27.0 cm
- Baking tray, Ø approx. 28.0 cm
- 90 minute timer with end signal
- Child lock
- Oven light

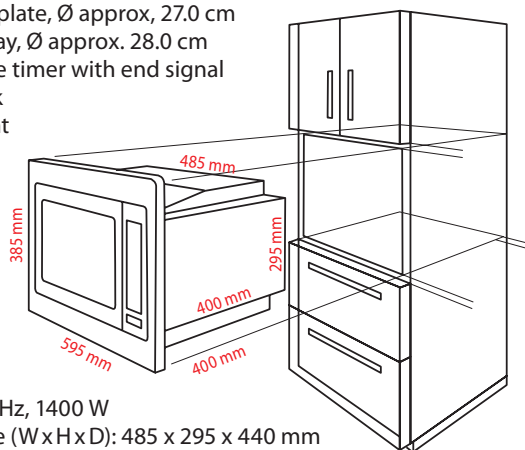

- 230 V, 50 Hz, 1400 W
- Appliance (W x H x D): 485 x 295 x 440 mm
- Appliance with frame (W x H x D): 595 x 385 x 440 mm
- Weight: approx. 17.5 kg

Art. no. 622 671
EAN 4 004 470 226 713 PU 1



Art. no. 622 691
EAN 4 004 470 226 911 PU 1





Stainless steel

Single hotplate EKP 5027 CB

- Hotplate, Ø approx. 180 mm, 1500 watt
- Infinitely adjustable thermostat
- Indicator light
- Heat-resistant finish
- High stability
- 230 V, 50 Hz, 1500 W
- W x H x D approx. 360 x 70 x 285 mm

Double hotplate DKP 5028 CB

- 2 hotplates
 - 1 x Ø approx. 180 mm, 1500 watt
 - 1 x Ø approx. 150 mm, 1000 watt
- 2 continuously variable thermostats
- 2 indicator lights
- Heat-resistant finish
- High stability
- 230 V, 50 Hz, 2500 W
- W x H x D approx. 570 x 70 x 285 mm

NEW! Stainless steel double hotplate DKP 5033 E CB

- Stainless steel housing
- 2 hotplates
 - 1 x Ø approx. 185 mm, 1500 watt
 - 1 x Ø approx. 155 mm, 1000 watt
- 2 continuously variable thermostats
- 2 indicator lights
- Incl. 2 mountable cool touch handles
- High stability
- 230 V, 50 Hz, 2500 W
- W x H x D approx. 590 x 70 x 280 mm (with handles)



Single induction hotplate EKI 5026 CB

- Induction hotplate with high-quality, eco-friendly glass-ceramic-surface
- Heating only takes seconds thanks to induction technology
- Scratch-resistant smooth cooking area, very easy to clean
- ECO-Save – 55 % time savings compared to conventional cooking plates, no preheating phase, energy saving
- Automatic pot detection – automatic switch-off in the case of non-induction pots
- 10 power level and 10 temperature level with LED indication (60° C – 240° C)
- Electronic sensor touch control panel with display for comfortable operation
- 3 LED indicator lights
- 180 minute timer with automatic switch-off and end signal
- Countdown indication
- Automatic switch-off after 120 min. without operation
- Automatic switch-off after removal of the pot
- Child lock
- High stability due to non-slip feet
- 220–240 V, 50/60 Hz, 2000 W
- W x H x D approx. 290 x 65 x 370 mm

Single induction hotplate EKI 5014 CB

- Induction hotplate with high-quality, eco-friendly Schott-Ceran® glass-ceramic surface
- Heating only takes seconds thanks to induction technology
- Scratch-resistant smooth cooking area, very easy to clean
- ECO-Save – 55 % time savings compared to conventional cooking plates, no preheating phase, energy-saving
- Automatic pot detection – automatic switch-off in the case of non-induction pots
- 10 power level and 10 temperature level
- Electronic control panel with display
- Easy to handle because of oversized buttons
- Power indication on LED display
- 180 minute timer with automatic switch-off and end signal
- Automatic switch-off after 120 min. without operation
- Automatic switch-off 15 sec. after removal of the pot
- 7 LED indicator lights
- High stability due to non-slip feet
- 230 V, 50 Hz, 2000 W
- W x H x D approx. 280 x 65 x 360 mm

Double induction hotplate DKI 5029 CB

- Induction double hotplate with high-quality, eco-friendly glass-ceramic-surface
- Heating only takes seconds thanks to induction technology
- Scratch-resistant smooth cooking area (very easy to clean)
- ECO-Save – 55% time savings compared to conventional cooking plates, no preheating phase, energy saving
- Automatic pot detection – automatic switch-off in the case of non-induction pots
- LED display
- Each hob with 16 function levels – 6 power levels and 10 temperature levels (60 °C–240 °C)
- Electronic Sensor Touch control panel with display for comfortable operation
- 2x 3 LED indicator lights
- 180 minute timer with automatic switch-off and end signal
- Countdown indication on the LED display
- Automatic switch-off after 120 min. without operation
- Automatic switch-off after removal of the pot
- High stability due to non-slip feet
- 220–240 V, 50/60 Hz, 3500 W max.
- W x H x D approx. 610 x 75 x 365 mm

● Art. no. 650 261
EAN 4 004 470 502 619 PU 4



● Art. no. 650 141
EAN 4 004 470 501 414 PU 2



● Art. no. 650 291
EAN 4 004 470 502 919 PU 2



MC 701 CB



MC 702 CB



Textile cleaner

MC 701 CB / MC 702 CB

73

MC 701 CB

- Ideal for the easy removal of lint/pilling
- Handy size
- Metal lint grid
- Transparent lint container
- On/off switch
- Battery operation: 2x 1.5 V (AA) (batteries not included)
- WxHxD approx. 36 x 76 x 76 mm

MC 702 CB

- Ideal for the easy removal of lint/pilling
- Handy size
- Metal lint grid
- Transparent lint container
- On/off switch
- Battery operation: 2x 1.5 V (AA) (batteries not included)
- WxHxD approx. 60 x 85 x 170 mm

● Art. no. 607 010 (MC 701 CB)
 EAN 4 004 470 070 101 PU 20
 ● Art. no. 607 020 (MC 702 CB)
 EAN 4 004 470 070 200 PU 20





74

Steam iron DB 785 CB

- Special stainless steel sole plate
 - Steam jet function, spray device and vertical steam
 - Variable temperature control
 - Continuous steam regulation
 - Dry function (steam can be switched off)
 - Practical self-cleaning function
 - Transparent water container (approx. 135 ml)
 - Cable attached via 360° turnable joint
 - Indicator light
- 220–240 V, 50/60 Hz, 1700 W
 - WxHxD approx. 110 x 140 x 260 mm

Steam iron DB 765 CB

- Special stainless steel sole plate
 - Steam jet function, spray device and vertical steam
 - Variable temperature control
 - 3-level steam control
 - Dry function (steam can be switched off)
 - Practical self-cleaning function
 - Transparent water container (approx. 130 ml)
 - Cable attached via 360° turnable joint
 - Indicator light
- 230 V, 50 Hz, 2000 W
 - WxHxD approx. 115 x 155 x 275 mm

Steam iron DB 780 CB

- Special stainless steel sole plate
 - Steam jet function, spray device and vertical steam
 - Variable temperature control
 - Continuous steam regulation
 - Dry function (steam can be switched off)
 - Practical self-cleaning function
 - Transparent water container (approx. 200 ml)
 - Cable attached via 360° turnable joint
 - Indicator light
- 220–240 V, 50/60 Hz, 2200 W
 - WxHxD approx. 110 x 150 x 275 mm

Art. no. 607 850
EAN 4 004 470 078 503

PU 6



Art. no. 607 650
EAN 4 004 470 635 287

PU 6



Art. no. 607 800
EAN 4 004 470 078 008

PU 6





Steam iron
DB 766 CB

- Special stainless steel sole plate
- Steam jet function, spray device and vertical steam
- Variable temperature control
- Steam control
- Dry function (steam can be switched off)
- Anti-calc system
- Anti-drip function
- Practical self-cleaning function
- Transparent water container (approx. 200 ml)
- Open, rubberised handle
- Cable attached via 360° turnable joint
- Indicator light

- 220–240 V, 50/60 Hz, 2500 W
- WxHxD approx. 124 x 144 x 280 mm



Steam iron
DB 784 CB

- Special stainless steel sole plate
- 7 functions:
 - Spray device
 - Steam jet function
 - Vertical steam
 - Dry function (steam can be switched off)
 - Self-cleaning function (switchable)
 - Anti-drip function
 - Anti-calc system
- Variable temperature control
- Continuous steam regulation
- Transparent water container (approx. 360 ml)
- Cable attached via 360° turnable joint
- Indicator light

- 220–240 V, 50/60 Hz, 2500 W
- WxHxD approx. 115 x 150 x 290 mm



Ceramic

Steam iron DB 781 CB

- Scratch-resistant ceramic sole plate with outstanding sliding behaviour
 - 5 functions:
 - Spray device
 - Steam jet function
 - Vertical steam
 - Dry function (steam can be switched off)
 - Self-cleaning function (switchable)
 - Variable temperature control
 - Continuous steam regulation
 - Transparent water container (approx. 250 ml)
 - Cable attached via 360° turnable joint
 - Indicator light
 - Measuring cup
- 220–240 V, 50/60 Hz, 1800–2200 W
 ■ WxHxD approx. 118 x 134 x 280mm



Easy-running, scratch-resistant ceramic sole plate



Ceramic

Steam iron DB 782 CB

- Scratch-resistant ceramic sole plate with outstanding sliding behaviour
 - 7 functions:
 - Spray device
 - Steam jet function
 - Vertical steam
 - Dry function (steam can be switched off)
 - Self-cleaning function (switchable)
 - Anti-drip function
 - Anti-calc filter system
 - Variable temperature control
 - 4-level steam control (0-1-2-3)
 - Transparent water container (approx. 360 ml)
 - Rubberised handle for non-slip handling
 - Rubberised rest for excellent stability
 - Cable attached via 360° turnable joint
 - Indicator light
- 220–240 V, 50/60 Hz, 2400–2800 W
 ■ WxHxD approx. 120 x 160 x 300 mm



Easy-running, scratch-resistant ceramic sole plate

Art. no. 607 810
 EAN 4 004 470 078 107 PU 6



Art. no. 607 820
 EAN 4 004 470 078 206 PU 6





Ceramic



ELECTRONIC

Ceramic

Steam ironing unit DBS 792 CB

- Scratch-resistant ceramic sole plate with outstanding sliding behaviour
 - Constantly high temperature and optimal steam generation
 - Even and consistent heat distribution through 20 steam nozzles
 - With steam jet function (horizontal and vertical)
 - Constant high steam output: max. 80 g/min.
 - Removable water tank (2.3 litre capacity), in case of average operation sufficient for approx. 90 minutes
 - Permanent refill function – refilling of the water tank during the operation possible
 - Continuously adjustable temperature control
 - 2 anti-scale cartridges
 - Extra large rest plate to provide the iron with a stable rest
 - Arrestable holding device
 - Long connection cable
 - Cable take-up on the base
- 220–240 V, 50/60 Hz, 2000–2400 W
 - W x H x D approx. 205 x 315 x 365 mm

NEW! Steam ironing unit DBS 1793 CB

- Scratch-resistant ceramic sole plate with outstanding sliding behaviour
 - Electronic
 - Control LCD display (blue illuminated) for indication of: steam, change indicator (anti-scale cartridge), service interval
 - Constantly high temperature and optimal steam generation
 - Even and consistent heat distribution through 20 spray nozzles
 - With steam jet function (horizontal and vertical)
 - Constant high steam output: max. 80 g/min.
 - Removable water tank (2.3 litre capacity), in case of average operation sufficient for approx. 90 minutes
 - Permanent refill function – refilling of the water tank during the operation possible
 - Continuously adjustable temperature control
 - Incl. 2 anti-scale cartridges
 - Extra large rest plate to provide the iron with a stable rest
 - Arrestable holding device
 - Long connection cable
 - Cable take-up on the base
- 220–240 V, 50/60 Hz, 2000–2400 W
 - W x H x D approx. 205 x 315 x 365 mm



Scratch resistant and smooth running ceramic sole plate



Removable water tank (2.3 litre capacity)



Replacement cartridge for DBS 792 CB and DBS 1793 CB

Art. no. 8 936 110
EAN 4 006 160 632 606



Scratch resistant and smooth running ceramic sole plate



Removable water tank (2.3 litre capacity)



Control LCD display (blue illuminated)

● Art. no. 607 927
EAN 4 004 470 079 272
● Art. no. 607 921
EAN 4 004 470 079 210

PU 2

PU 2

● Art. no. 617 933
EAN 4 004 470 179 330

PU 2





Detachable 1.2 litre capacity water tank

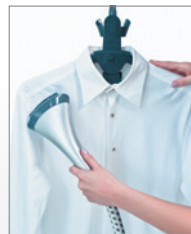

Vertical steam ironing for hanging clothes



Gentle and effective method for removing creases from fabrics

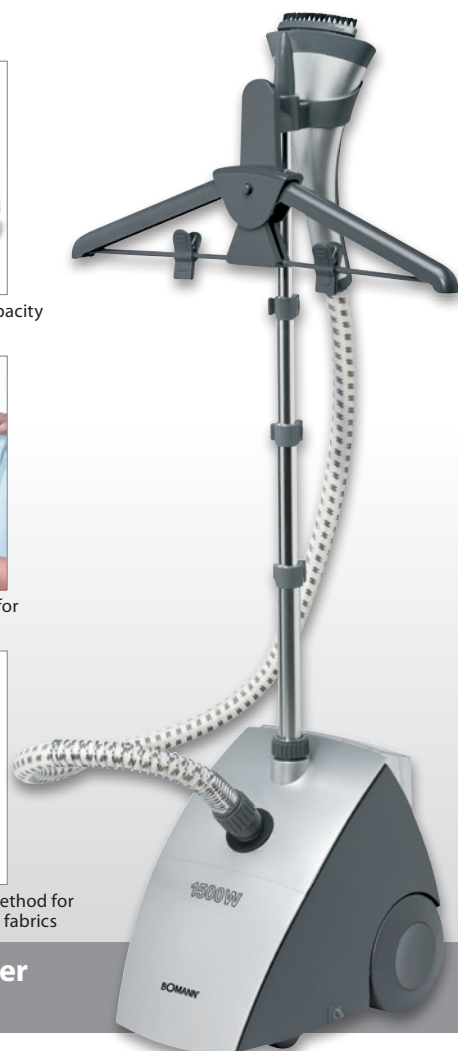

Mini-washing machine MWA 9485 CB

- Light mini-washing machine
- Obviates the need for tedious hand washing at home and when travelling
- Ideal for both small washes and for sensitive laundry items
- Washes quickly and effectively with a consistent result
- Low water, electricity and detergent consumption
- Ideally suited for camping, holidays and single households
- 15 minute timer
- Incl. drainage hose and water inlet
- Capacity: 13 litre max. / 1.5 kg
- 230 V, 50 Hz, 135 W
- WxHxD approx. 330 x 460 x 360 mm



15 minute timer



Incl. water inlet and drainage hose



Water level indicator

Fabric steamer TDC 321 CB

- Steamer for steam ironing, removes wrinkles and lint
- Gentle and effective method for removing creases from fabrics
- The gentle steam effect extends the lifespan of your clothes
- Saves time over traditional ironing
- Also suitable for sensitive materials
- Vertical steam function
- Quick warm-up time through 1500 watt of power – ready to use in around 50 seconds
- Detachable 1.2 litre capacity water tank
- Use for up to 40 mins on a full tank
- Steplessly height-adjustable telescopic pole (to 1.35 m) for individual adjustment to body height and for easy storage
- Constant steam output: around 30 g/min.
- Vertical steam ironing for hanging clothes, curtains etc.
- Anti-drip system
- Easy to transport – through 2 large rollers and 2 360° casters
- Accessories: Trousers and clothes hanger, brush head, fabric brush attachment for removing wrinkles and bobbles
- On/off switch (illuminated)
- Overheating protection
- Fire protection fuse
- Cable length approx. 1.80 m
- 230 V, 50 Hz, 1500 W
- BxHxT ca. 340 x 1640 x 230 mm

Art. no. 694 850
EAN 4 004 470 948 509

PU 1



Art. no. 603 211
EAN 4 004 470 032 116

PU 1





Steam cleaner DR 905 CB

- Steam cleaner, cleans, disinfects and degreases without limescale residues and cleaning strip
- 3.5 bar max. steam pressure
- Approx. 300 ml water tank
- Extra-long cable (approx. 5 m)
- Overpressure protection
- Overheating protection
- Includes 9 accessories: 2x brush, nozzle, angle, fleece and windowcleaning attachments, hose, measuring beaker
- 220–240 V, 50/60 Hz, 1000 W
- WxHxD approx. 260 x 230 x 145 mm



2x round brush attachment



Jet nozzle attachment



Universal cleaning attachment



Angle attachment



Fleece



Measuring cup

Steam cleaner DR 906 CB

- Steam cleaner, cleans, disinfects and degreases without limescale residues and cleaning strip
- 3.5 bar max. steam pressure
- Approx. 600 ml water tank
- Aluminum boiler
- Indicator light (mains and standby)
- Safety tank lid with pressure relief valve
- Overheating protection
- On/off switch protected against water spray
- Practical carrying handle
- Smooth-running wheels
- Steam control on the handle
- Incl. 9 accessories: 2-part extendable insertable tube, floor brush, non-woven cloth, window wiper, jet nozzle attachments, round brush attachment, funnel, measuring beaker
- 230 V, 50/60 Hz, 1350 W
- WxHxD approx. 230 x 310 x 320 mm

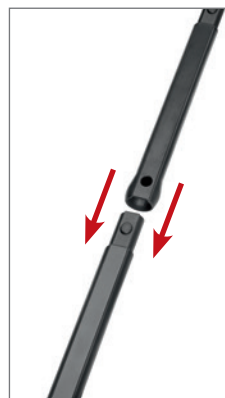

Extendable insertable tube



Floor brush



Round brush attachment



Window wiper



Angle attachment



Fleece attachment for thorough cleaning



Window-cleaning attachment, cleans without streaks and limescale residue



Accessories: 2x microfiber cloth, measuring beaker, window cleaner, nozzle, brush, carpet glider attachment

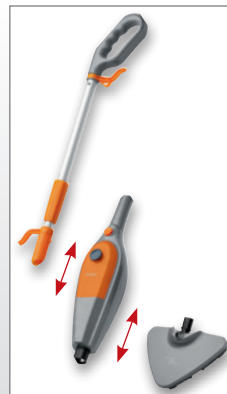

Space-saving storage by easy separation of the components



Steam mop DR 904 CB



- Mobile high-pressure cleaner with 2 large wheels for use in areas of gentle care like cars, motorcycles, bicycles, and also for powerful cleaning, such as sidewalks, garden furniture/ tools, etc.
- Approx. 90 bar
- Delivery volume: 300 l max./h (5 l max./min.)
- Area capacity: approx. 20 m²/h
- Inlet temperature: 40 °C max.
- 1400 W max.
- Integrated water filter for protection of the pump against entry of dirt
- Large work reach by 5 m long connection cable and 5 m long high-pressure hose
- Compact housing with low weight (5.7 kg)
- Quick, clean and easy use of detergents with the practical detergent bottle (300 ml)
- Adjustable high-pressure nozzle ■ High-pressure gun
- On/off switch (splashproof)
- Practical cable and hose winding on the unit for clean and space-saving storage
- Additional accessories can be stored on the unit
- Incl. carrying handle
- 230 V, 50 Hz, 1400 W
- W x H x D approx. 255 x 480 x 245 mm



Incl. cleaning agent bottle (300 ml)



Incl. practical cable reel



Mobile use – gentle and powerful cleaning

- Steam cleaner cleans, disinfects and removes grease at 100 °C without grease marks and residues
- Suitable for different surfaces: e.g. laminates, wooden floors, marble, rubber, slate, ceramics
- Cleans fabric surfaces such as carpets, mats and cushions
- Environmentally friendly and hygienic cleaning without the use of chemicals
- Kills bacteria through high steam power
- Maximum disinfection and intensive cleaning
- Ready to use in around 30 seconds
- Approx. 300 ml water tank
- Use for up to 30 min. on a full tank
- Up to 25 g steam/min.
- Carpet glider attachment
- Aluminium telescopic tube
- Removable handle and nozzle for easy use by hand
- Accessories: 2x microfiber cloth, measuring beaker, window cleaner, nozzle, brush
- Long lead, approx. 5.0 m
- Electric lead take-up
- Fire protection fuse
- 220–240 V, 50/60 Hz, 1500 W
- W x H x D approx. 260 x 1200 x 210 mm

Art. no. 690 131
EAN 4 004 470 901 313 PU 1



Art. no. 609 041
EAN 4 004 470 090 413 PU 3





Incl. spraying bottle



Window cleaner
WC 908 CB

Battery vacuum cleaner
CB 967

- Rechargeable battery-operated window cleaner set for daily use
- Streak-free, time-saving, and hygienic cleaning for example of flat surfaces, windows, glass doors, mirrors, shower stalls, car windows etc.
- 2-in-1 cleaning/suction function
 - drip-free cleaning by 270 mm wide suction nozzle
 - thorough cleaning by 310 mm wide micro fleece attachment
- High-power ni-mh battery for up to 40 min. cleaning time
- Included spraying bottle and micro fleece attachment (machine-washable)
- Easy handling because of low weight (600 g)
- Charging power supply: 230–240 V, 50/60 Hz
- Battery: 3.6 V, 1500 mAh
- W x H x D approx. 270 x 110 x 360 mm

- With 3 rechargeable Ni-Mh batteries
- Nozzle for small gaps, brush nozzle
- Permanent dust filter, washable
- Charge control lamp (LED)
- Charger mains adapter
- Foot/wall mounting (installation materials not supplied)
- Charger mains adapter: 230 V, 50 Hz
- Rechargeable battery: 3.6 V, 1400 mAh
- W x H x D approx. 100 x 130 x 310 mm



Micro fleece cloth pad for cleaning (310 mm, removable)

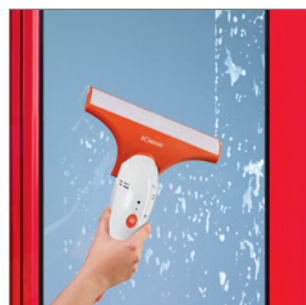

Width suction nozzle for cleaning free of streak (270 mm)



Art. no. 609 081
EAN 4 004 470 090 819

PU 4



Art. no. 609 670
EAN 4 004 470 096 705

PU 6





82

Battery wet/dry vacuum cleaner AKS 960 CB

- Wet/dry vacuum cleaner
- Powerful battery vacuum cleaner with three rechargeable batteries
- Permanent dust filter, washable
- Charge indicator light (LED)
- Charger mains adapter
- Accessories: Recess nozzle, attachment for wet vacuuming, wall mounting
- Charger mains adapter: 230 V, 50 Hz
- Rechargeable battery: 3.6 V, 1400 mAh
- WxHxD approx. 110 x 130 x 380 mm



Battery vacuum cleaner AKS 713 CB

- Wet/dry vacuum cleaner
- Powerful battery vacuum cleaner with 10 rechargeable batteries
- Permanent dust filter (washable)
- Charge control lamp (LED)
- 12 V and battery operation possible
- Direct-Drive function: with fully discharged battery, the vacuum cleaner can be used immediately in 12 V operation
- Cable storage compartment
- Accessories: 2x crevice nozzle (1x 13 cm, 1x 26 cm), attachment for wet vacuuming, brush nozzle, 12 V adapter cable
- Charger mains adapter: 230 V, 50 Hz
- Rechargeable battery: 12 V / Battery (NiMh), 1400 mAh
- WxHxD approx. 125 x 130 x 400 mm

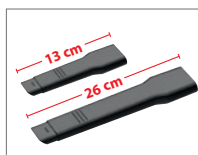

Extra-long crevice nozzles, for example, for use in the car



Attachment for wet vacuuming



360° brush nozzle

Hand vacuum cleaner CB 947

- Hand vacuum cleaner for vacuuming of: furniture, upholstery, frames, curtains, books, computers, cars, and much more
- Compact size: 24 x 12 x 15 cm
- Permanent dust filter
- Easy to clean
- Large operation range (6 m cable)
- Low weight
- Vertical storage (space saving)
- Accessories: flexible „vacuum snout“ with crevice nozzle, small and large brush, shoulder strap
- 230 V, 50 Hz, 700 W max.
- WxHxD approx. 110 x 185 x 360 mm



Art. no. 609 600
EAN 4 004 470 096 002

PU 6



Art. no. 607 139
EAN 4 004 470 071 399

PU 4



Art. no. 609 470
EAN 4 004 470 094 701

PU 6



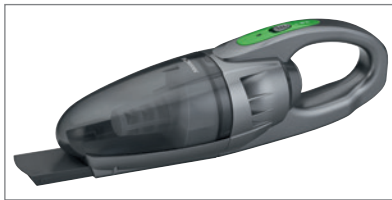

Incl. battery vacuum cleaner



Charging station suitable for wall mounting



Space-saving folding handle



2in1

NEW! Battery floor vacuum cleaner BS 1714 A CB



Incl. electrically rotating turbo floor brush

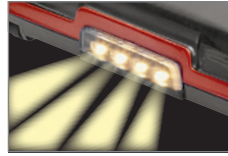

LED front light for better illumination of dark areas



Incl. flexible brush for corners and edges



2-fold accessories: combined brush/crevice nozzle

2in1

NEW! Battery floor vacuum cleaner BS 1949 A CB



- Accu-hand and floor vacuum cleaner, for flexible and individual operations as brush-/hand vacuum cleaner
 - Permanent dust filter (washable)
 - Powerful 12 V, 1800 mAh Accus
 - LED charge level indicator (illuminated)
 - 12 V and battery operation possible
 - Cable free (for flexible use)
 - 180° rotatable double joint for optimal mobility
 - Bagless filter technology
 - Incl. telescopic crevice nozzle and electrical, rotating turbo floor brush
 - Charging station suitable for wall mounting (incl. mounting material)
 - Space-saving folding handle
- Charger mains adapter: 100–240 V, 50/60 Hz
 - Rechargeable battery: 12 V, 1800 mAh
 - W x H x D approx. 130 x 1120 x 270 mm (extended)

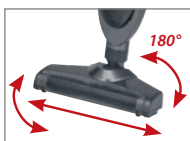

180° rotatable double joint for optimal mobility



Electrical, rotating turbo floor brush



- Accu-hand and floor vacuum cleaner, for flexible and individual operations as brush-/hand vacuum cleaner
 - Bagless Cyclon Twin Spin technique allows continual high suction power
 - Bagless filter technology
 - Powerful lithium-ion battery 21,6 V, 2200 mAh accu
 - Running time approx. 30 min
 - 2 suction levels (turbo function electrically switchable)
 - LED battery charge condition indicator (illuminated)
 - Cable free (for flexible use)
 - HEPA-Filter
 - Aluminium suction tube
 - Easy to clean
 - Low weight
 - Charging station suitable for wall mounting (incl. mounting material)
 - Incl. electrically rotating turbo floor brush with LED front light for better illumination of dark areas
 - Incl. flexible brush for corners and edges
 - Accessories: aluminium suction tube, wall mount, special brush, combined brush/crevice nozzle
- Charger mains adapter: 230–240 V, 50 Hz
 - Rechargeable battery: 21,6 V, 2200 mAh
 - W x H x D approx. 200 x 1050 x 260 mm (with suction tube)

Powerful Lithium-ion battery 21.6 V / 2200 mAh

Art. no. 617 141
EAN 4 004 470 171 419

PU 1



Art. no. 619 497
EAN 4 004 470 194 975

PU 2

Art. no. 619 496
EAN 4 004 470 194 968

PU 2





Incl. brush tool



Incl. crevice tool



Incl. wall mount



Big operating range
(6.5 m connection cable)

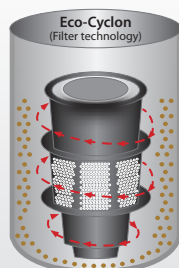

Eco-Cyclon filter technology

2in1

A



A



NEW! Floor vacuum cleaner
BS 1948 CB

NEW! Floor vacuum cleaner
BS 9021 CB

- 2 in 1 – Floor and hand vacuum cleaner
- Eco-Cyclon
- Also suitable as hand vacuum cleaner for vacuuming of: furniture, upholstery, frames, curtains, books, computers, cars and much more
- Multi filter system
- HEPA-Filter
- Two part aluminium tube (40–85 cm)
- Big operating range (6.5 m connection cable)
- Switchable floor brush
- Easy to clean
- Low weight
- Incl. wall mount (space saving)
- Accessories: Two part aluminium tube, wall mount, brush tool, crevice tool, floor brush
- 220–240 V, 50/60 Hz, 600 W
- W x H x D approx. 230 x 1300 x 130 mm (with suction tube)

- Floor vacuum cleaner with energy-saving 700 watt
- 4-fold microfilter system
- Metal telescopic tube
- Switchable floor brush
- Dust bag change indicator
- Practical carrying handle
- Automatic cable rewind
- Space-saving parking aid
- Dual accessory: combined brush/crevice nozzle
- 220–240 V, 50/60 Hz, 700 W
- W x H x D approx. 245 x 229 x 316 mm

Spare bags:

SSB 101
Art. no. 282 047
EAN 4 006 160 820 478



Incl. floor brush (switchable)

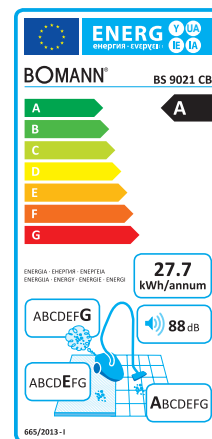
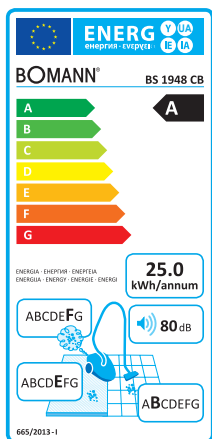

● Art. no. 619 489
EAN 4 004 470 194 890 PU 2
● Art. no. 619 483
EAN 4 004 470 194 838 PU 2

● Art. no. 690 211
EAN 4 004 470 902 112 PU 1





Floor vacuum cleaner
BS 9019 CB

- Floor vacuum cleaner with energy-saving 700 watt
 - 5-layer micro-filter system
 - Stainless steel suction tube
 - Switchable floor brush
 - Dust bag change indicator
 - Practical carrying handle
 - Automatic cable rewind
 - Space-saving parking aid
 - 2-fold accessories: combined brush/crevice nozzle
- 220–240 V, 50/60 Hz, 700 W
■ WxHxD approx. 256 x 205 x 310 mm

Spare bags:

SSB 98
Art. no. 282 193
EAN 4 006 160 821 932

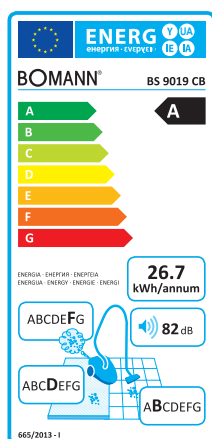

ELECTRONIC

Floor vacuum cleaner
BS 9014 CB

- Electronic power adjustment
 - 4-layer micro-filter system
 - Includes HEPA exhaust filter
 - Stainless steel suction tube (approx. 84 cm length)
 - Extra large operation range (approx. 8.30 m)
 - Switchable floor brush
 - Dust bag change indicator
 - Rubberized rollers (ideal for sensitive floors)
 - Practical carrying handle
 - Automatic cable rewind
 - Space-saving parking aid
 - Integrated accessory tray
 - 2-fold accessories: combined brush/crevice nozzle
- 220–240 V, 50/60 Hz, 800 W
■ WxHxD approx. 255 x 205 x 370 mm

Spare bags:

SSB 98
Art. no. 282 193
EAN 4 006 160 821 932

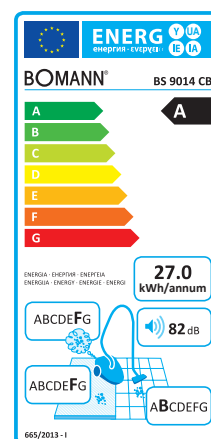



Floor vacuum cleaner
BS 9010 CB

Floor vacuum cleaner
BS 9020 CB

- Electronic power adjustment
 - 4-layer micro-filter system
 - Includes HEPA exhaust filter
 - Stainless steel suction tube (approx. 85 cm length)
 - Extra large operation range (approx. 8.30 m)
 - Switchable floor brush
 - Dust bag change indicator
 - Rubberized rollers (ideal for sensitive floors)
 - Practical carrying handle
 - Automatic cable rewind
 - Space-saving parking aid
 - Integrated accessory tray
 - 2-fold accessories: combined brush/crevice nozzle
- 230 V, 50 Hz, 800 W
■ W x H x D approx. 280 x 240 x 460 mm

Spare bags:

SSB 101
Art. no. 282 047
EAN 4 006 160 820 478

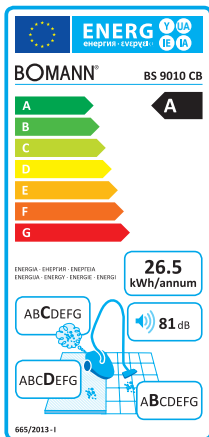

- Floor vacuum cleaner with energy-saving 700 watt
 - Electronic power adjustment
 - 5-layer micro-filter system
 - Includes HEPA exhaust filter
 - Stainless steel suction tube (approx. 84 cm length)
 - Extra large operation range (approx. 8.30 m)
 - Switchable floor brush
 - Incl. parquet brush
 - Dust bag change indicator (electronic)
 - Rubberised rollers (ideal for sensitive floors)
 - Practical carrying handle
 - Automatic cable rewind
 - Space-saving parking aid
 - 3-fold accessories: crevice nozzle, upholstery nozzle, 360° brush attachment
- 220-240 V, 50/60 Hz, 700 W
■ W x H x D approx. 291 x 246 x 457 mm

Spare bags:

SSB 101
Art. no. 282 047
EAN 4 006 160 820 478

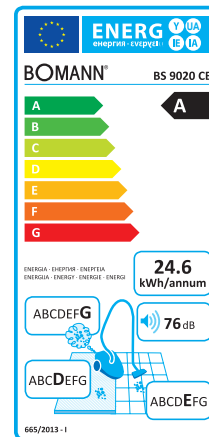



A  **ELECTRONIC**

A 

Floor vacuum cleaner
BS 9015 CB

NEW! **Floor vacuum cleaner**
BS 9022 CB

- Floor vacuum cleaner with energy-saving 700 watt
 - Electronic power adjustment
 - 4-layer micro-filter system
 - Includes HEPA exhaust filter
 - Stainless steel suction tube (approx. 84 cm length)
 - Extra large operation range (approx. 8.30 m)
 - Switchable floor brush
 - Dust bag change indicator
 - Rubberized rollers (ideal for sensitive floors)
 - Practical carrying handle
 - Automatic cable rewind
 - Space-saving parking aid
 - 2-fold accessories: combined brush/crevice nozzle
- 220–240 V, 50/60 Hz, 700 W
■ WxHxD approx. 295 x 215 x 450 mm

- Eco-Cyclon floor vacuum cleaner with energy-saving 700 Watt
 - Bagless filter technology
 - 4-fold microfilter system
 - Includes HEPA filter
 - Metal telescopic tube
 - Switchable floor brush
 - Rubberized rollers (ideal for sensitive floors)
 - Practical carrying handle
 - Automatic cable rewind
 - Space-saving parking aid
 - Dual accessory: combined brush/crevice nozzle
- 220–240 V, 50/60 Hz, 700 W
■ WxHxD approx. 235 x 290 x 365 mm

Spare bags:

SSB 101
Art. no. 282 047
EAN 4 006 160 820 478

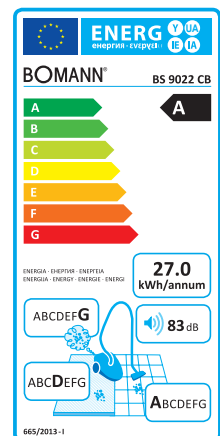
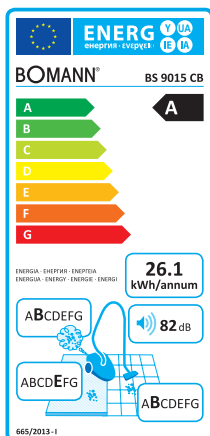

Art. no. 690 151
EAN 4 004 470 901 511 PU 1

Art. no. 690 223 EAN 4 004 470 902 235 PU 1
Art. no. 690 227 EAN 4 004 470 902 273 PU 1
Art. no. 690 226 EAN 4 004 470 902 266 PU 1





A **ELECTRONIC**

A **ELECTRONIC**

NEW! Floor vacuum cleaner
BS 9027 CB

Floor vacuum cleaner
BS 9018 CB

- Eco-Cyclon twin spin floor vacuum cleaner with energy-saving 700 Watt
 - Bagless Cyclon Twin Spin technique allows continual high suction power
 - Electronic power adjustment
 - 4-fold filter system
 - Stainless steel telescopic tube (approx. 92 cm length)
 - Extra-large operation range (approx. 8.30 m)
 - Switchable floor brush
 - Incl. parquet brush
 - Rubberised rollers (ideal for sensitive floors)
 - Practical carrying handle
 - Automatic cable rewind
 - Space-saving parking aid
 - Dual accessory: combined brush/crevice nozzle
- 220–240 V, 50/60 Hz, 700 W
■ W x H x D approx. 250 x 330 x 380 mm

- Floor vacuum cleaner with energy-saving 700 Watt
 - Electronic power adjustment
 - Includes 2 HEPA filter
 - Height-adjustable telescopic tube
 - Switchable floor brush
 - Bagless filter technology (no need to purchase dust bags)
 - Easy-to-empty, transparent dust-collecting container replaces conventional dust bag
 - Tank volume: 1.25 l
 - Motor protection filter (washable)
 - Rubberised rollers (ideal for parquet floors)
 - Automatic cable rewind
 - Space-saving parking aid
 - 3-fold accessories: combined brush/crevice nozzle, upholstery nozzle
- 220–240 V, 50/60 Hz, 700 W
■ W x H x D approx. 365 x 265 x 285 mm



Incl. parquet brush

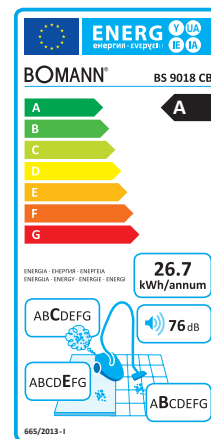
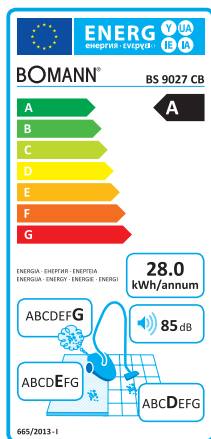

- Art. no. 690 276
EAN 4 004 470 902 761 PU 1
- Art. no. 690 277
EAN 4 004 470 902 778 PU 1
- Art. no. 690 279
EAN 4 004 470 902 792 PU 1

- Art. no. 609 187
EAN 4 004 470 901 870 PU 1





2in1



Stainless steel



Wet and dry vacuum cleaner

BS 9000 CB

- Stainless steel housing
 - Large and comfortable wet and dry vacuum cleaner with powerful 1400 watt max.
 - Tank capacity: approx. 20 litres
 - Multi filter system
 - Incl. blower function, e.g. for easy removal of leaves
 - Draws coarse dirt as effectively as liquids
 - Optimal stability through 4 rollers
 - Deflection rollers (360°) allow smooth and flexible working
 - 2-part robust suction tube
 - Overflow protection by float valve
 - Practical holder on the vacuum cleaner for quick access and tidied accessory
 - 5 m cable allows large operation range
 - Accessories: brush/crevice nozzle, wet/dry brush, washable permanent filter
- 220–240 V, 50/60 Hz, 1200–1400 W
 - W x H x D approx. 405 x 530 x 405 mm



Also ideal for the use on laminate, carpets etc.



Accessories: brush nozzle and crevice nozzle

Electronic bathroom scale

PW 1417 CB

- Electronic glass bathroom scale with easy-to-read LCD display
 - Weighing units in kg, lb, st (convertible)
 - Measurement range of 2.5–150 kg (subdivided into 100 g steps)
 - Low-maintenance standing surface
 - Non-slip feet ensuring secure base
 - Automatic switch-off (prolongs battery life)
- Battery operation: 1x CR 2032 (battery not included)
 - W x H x D approx. 330 x 25 x 300 mm



90

Electronic bathroom scale PW 1418 CB

- Electronic glass bathroom scale with easy-to-read LCD display
- Weighing units in kg, lb, st (convertible)
- Measurement range of 2.5–150 kg (subdivided into 100 g steps)
- Low-maintenance standing surface
- Non-slip feet ensuring secure base
- Automatic switch-off (prolongs battery life)
- Battery operation: 1x CR 2032 (battery not included)
- W x H x D approx. 320 x 25 x 320 mm

Foot massager FM 8000 CB

- Intense whirlpool effect
- Massage burls for stimulating the foot reflex zones
- Additional massage roller, detachable, for selective foot reflex zone massage
- Heated footrest
- 4-level switches:
 - 0 = off
 - 1 = massage,
 - 2 = warm/whirl
 - 3 = warm/whirl/massage
- Can be used with and without water
- Splash guard, detachable
- Water level mark
- Spout
- Large rubber feet for slip-proof stand
- 230 V, 50 Hz, 90 W
- W x H x D approx. 300 x 120 x 380 mm



● Art. no. 614 181
EAN 4 004 470 141 818 PU 6



○ Art. no. 680 000
EAN 4 004 470 800 005 PU 3





2in1

Nose and ear hair remover NE 8008 CB

Hair and beard trimmer HSM 8006 CB

Hair trimmer set HSM 8007 NE CB

- Conveniently and simply removes troublesome hairs in the nose and ears
- Includes light for improved personal grooming
- Removable fine-steel shearing head for cleaning
- On/off switch
- Incl. covering cap for the shearing head

- Battery operation: 1x 1.5 V (AA) (batteries not included)
- WxHxD approx. 30 x 130 x 35 mm

- Stainless steel precision shaving head for uniform haircut
- Stainless steel blade
- Stepless cutting length adjustment for efficient use of the comb attachments
- 4 comb attachments: 3, 6, 9, 12 mm
- Rubberized inlay for non-slip handling
- Accessories:
 - 4 comb attachments
 - Cleaning brush
 - Shearing head protection
 - Hanging loop

- 230–240 V, 50 Hz, 9 W
- WxHxD approx. 65 x 200 x 55 mm

- Hair and beard trimmer:**
- Stainless steel precision shaving head for uniform haircut
 - Stainless steel blade
 - Stepless cutting length adjustment for efficient use of the comb attachments
 - 4 comb attachments: 3, 6, 9, 12 mm
 - Soft touch inlay for non-slip handling
 - Accessories: 4 comb attachments, cleaning brush, shearing head protection, comb, hanging loop
 - 230–240 V, 50 Hz, 9 W
 - WxHxD approx. 65 x 200 x 55 mm
- Nose and ear hair remover:**
- Gently and comfortably removes unsightly nose and ear hair
 - Stainless steel shaving head, can be detached for cleaning
 - Incl. cap for shaving head
 - Battery operation: 1x 1.5 V (AA) (batteries not included)
 - WxHxD approx. 30 x 130 x 30 mm



Includes light for improved personal grooming
Promotional Packaging



● **Art. no. 680 080**
EAN 4 004 470 800 807 PU 12

● **Art. no. 680 061**
EAN 4 004 470 800 616 PU 12

● **Art. no. 680 071**
EAN 4 004 470 800 715 PU 10





Hot air styler
CB 856

- 2 power level
- Roll key for accessories
- Ergonomically formed
- Cable with swivel cord 360°
- Safety cut-out

- 220–240 V, 50 Hz, 300 W
- W x H x D approx. 320 x 50 x 50 mm

Hot air styler
HAS 887 CB

- Powerful 500 watt motor
- 2 power level + cold level Cool Shot
- Incl. 3 accessories: volume styler, round brush, regular brush
- Roll-out button for attachments
- Switchable voltage
- Overheating protection

- 115/220–240 V, 50/60 Hz, 500 W
- W x H x D approx. 305 x 45 x 45 mm



Incl. volume styler, round brush, regular brush



Travelling hair dryer
CB 818

- Compact sports hair dryer
- 2 power level
- Removable shaping nozzle
- Switchable voltage
- Ring for hanging up
- Practical transparent bag
- 120/220–240 V, 50/60 Hz, 1200 W
- WxHxD approx. 130 x 195 x 70 mm

Hair dryer
HT 8002 CB

- Compact travelling hair dryer
- 2 temperature/power settings
- Removable shaped nozzle, rotatable through 360°
- Rubber profile on the casing avoid slipping
- Overheating protection
- Hanging loop
- 230 V, 50 Hz, 1200 W
- WxHxD approx. 111 x 210 x 75 mm

Hair dryer
HTD 8005 CB

- Compact travelling hair dryer
- Folding handle
- 2 temperature/power settings
- Removable shaped nozzle, rotatable through 360°
- Soft touch housing – rubberised surface to prevent slipping when putting down
- Includes volume diffuser and see-through bag for practical storage and when travelling
- Switchable voltage: 110/230 V
- Hanging loop
- 110/230 V, 50/60 Hz, 1100–1200 W
- WxHxD approx. 170 x 235 x 75 mm



Art. no. 608 189
EAN 4 004 470 081 893

PU 12



Art. no. 680 029
EAN 4 004 470 800 296

PU 12



Art. no. Nr. 680 056
EAN 4 004 470 800 562

PU 12





Ion technology function

94

Professional hairstyler HTD 889 CB

- Professional hairstyler with 2000 watt max.
- 3 temperature/power settings
- 2 speed settings
- Cool Shot
- Professional volume diffuser and shaping nozzle
- Air intake filter, removable
- Rubberised housing
- Avoid slipping
- Soft-touch grip
- Overheating protection
- Hanging loop
- 220–240 V, 50/60 Hz, 1800–2000 W
- WxHxD approx. 270 x 270 x 90 mm

Professional hairstyler HTD 899 CB

- Professional hairstyler with 2200 watt
- 3 temperature/power settings
- 2 speed level
- Cool Shot
- Professional volume diffuser and shaping nozzle
- Air intake filter, removable
- Screw-in handle (space-saving)
- Soft touch housing – rubberized surface prevents slipping
- Includes travel bag with pull cord
- Safety thermal cut-out
- Hanging loop
- 220–240 V, 50/60 Hz, 2200 W
- WxHxD approx. 245 x 255 x 85 mm

NEW! Hair dryer HT 1844 CB

- Professional hair dryer with powerful 2100 watt
- Ion technology function – improved possibilities of hairstyling thanks to antistatic effect, the hair is not dried out and becomes smooth and shiny
- 3 temperature/power settings
- 2 speed settings
- Cool Shot
- Shaped nozzle, 360° swiveling (removable)
- LED pilot lamp
- Overheating protection
- Hanging loop
- 230 V, 50 Hz, 2100 W
- WxHxD approx. 220 x 255 x 90 mm



Incl. travel bag



Screw-in handle

Art. no. 608 891
EAN 4 004 470 088 915 PU 6



Art. no. 608 996
EAN 4 004 470 089 967 PU 6



Art. no. 618 443
EAN 4 004 470 184 433 PU 6





Ø 23 cm

Table fan
VL 1137 CB

- Oscillating (can be switched off)
 - Adjustable angle of inclination
 - Metal protection grid
 - Safe base
 - Ø approx. 23 cm
 - 2 speed level
 - 3-level switches (0-1-2)
 - Practical carrying handle
- 220–240 V, 50/60 Hz, 30 W
■ WxHxD approx. 275 x 375 x 220 mm



Ø 30 cm

Table fan
VL 1138 CB

- Oscillating (can be switched off)
 - Adjustable angle of inclination
 - Metal protection grid
 - Safe base
 - Ø approx. 30 cm
 - 3 speed level
 - 4-level switches (0-1-2-3)
 - Practical carrying handle
- 220–240 V, 50/60 Hz, 40 W
■ WxHxD approx. 340 x 480 x 245 mm



Ø 40 cm

Standing fan
VL 1139 S CB

- Oscillating (can be switched off)
 - Height-adjustable
 - Adjustable angle of inclination
 - Metal protection grid
 - Safe base
 - Ø approx. 40 cm
 - 3 speed level
 - 4-level switches (0-1-2-3)
 - Practical carrying handle
- 220–240 V, 50/60 Hz, 45 W
■ WxHxD approx. 430 x 1250 x 640 mm

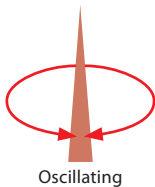

Oscillating

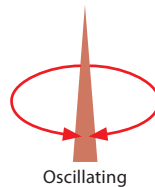

Oscillating

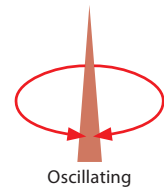

Oscillating

● **Art. no. 611 370**
EAN 4 004 470 611 373 PU 4



● **Art. no. 611 380**
EAN 4 004 470 611 380 PU 4



● **Art. no. 611 390**
EAN 4 004 470 611 397 PU 3





Air dehumidifier
LE 1150 CB

- Dehumidification power: 12 L/24 h
 - Air circulation in m³:
 - Level 1: approx. 100 m³/h
 - Level 2: approx. 140 m³/h
 - LED display (blue illuminated)
 - Humidity indicator
 - Electronic humidity control
 - The desired humidity can be set from 40 to 80 %
 - 24 hour timer
 - 1 L water tank (detachable)
 - Fold-out carrying handle
 - Convenient rollers
 - Automatic stop + warning signal with full tank
 - Low noise
 - Removable air filter (easy to clean)
 - Hose connector for permanent water drain
 - Incl. water hose (1 m)
 - On/off switch
 - Coolant: R134A
 - Ideal for rooms up to 15 m²
- 220–240 V, 50 Hz, 220 W
■ W x H x D approx. 280 x 520 x 185 mm



LED display



Hose connector for permanent water drain



Fan heater
HL 1095 CB

- 2 heat settings (1000/2000 watt max.)
 - Cold (ventilator)
 - Infinitely adjustable thermostat
 - Indicator light
 - 2 different ways of setting up
 - Safe base
 - Sturdy carrying handle
 - Overheating protection
- 220–240 V, 50 Hz, 1800–2000 W
■ W x H x D approx. 248 x 120 x 250 mm



2 different ways of setting up



Fan heater
HL 1096 CB

- 2 heat settings (1000/2000 watt)
 - Cold (ventilator)
 - Infinitely adjustable thermostat
 - Indicator light
 - Safe base
 - Sturdy carrying handle
 - Overheating protection
- 220–240 V, 50 Hz, 1800–2000 W
■ W x H x D approx. 230 x 138 x 262 mm

● **Art. no. 611 509**
EAN 4 004 470 115 093 PU 2



● **Art. no. 610 950**
EAN 4 004 470 109 504 PU 4



● **Art. no. 610 960**
EAN 4 004 470 109 603 PU 4





Ceramic fan heater HL 1097 CB

- PTC ceramic heater element for healthy, safe, quiet and efficient heating
 - Low dust accumulation
 - Quick and effective heating
 - Long service life
 - Robust and durable
 - 7 level switches
 - 2 heat settings (750/1500 W)
 - Oscillating (can be deactivated)
 - Cold setting (fan blower)
 - Steplessly adjustable thermostat
 - Safety switch for fire protection
 - Stable stand
 - Robust carry handle (foldable)
 - Overheat protection
- 220–240 V, 50 Hz, 1500 W
 - W x H x D approx. 191 x 267 x 141 mm



Oscillating

NEW! Ceramic fan heater HL 1120 CB

- PTC ceramic heater element for healthy, safe, quiet and efficient heating
 - Low dust accumulation
 - Quick and effective heating
 - Robust and insensitive by durable ceramic heater
 - 4 level switches
 - 2 heat settings (1000/2000 W)
 - Adjustable angle of inclination (90°)
 - Cold setting (fan blower)
 - Steplessly adjustable thermostat
 - High stability due to sturdy metal frame
 - Robust carry handle
 - Overheating protection
- 220–240 V, 50 Hz, 2000 W
 - W x H x D approx. 210 x 217 x 160 mm



A+

Cool box
KB 9486 CB

- Suitable for cooling and warming
 - Perfect for camping, travel and shopping
 - Capacity (gross capacity): ca. 25 litre max.
 - Even cooling by integrated fan
 - Powerful, maintenance-free Peltier cooling/heating system
 - Energy saving function
 - Double walled plastic casing with high quality isolation
 - Special sealing rubber in the lid reduces condensation
 - Control lights for cooling and warming function
 - Foldable handle
 - Removable lid
 - Accessory: 12 V connecting cable (detachable), 230 V connecting cable (detachable)
- Power supply:
- Mains adapter connection: DC 12 V, 40/48 W
 - Mains adapter connection: AC 220–240 V, ~ 50/60 Hz, 52/58 W, 11 W (ECO mode)
- WxHxD approx. 405 x 435 x 300 mm
- Energy class: A+



For all standard 0.75 / 1.0 / 1.5-litre bottles

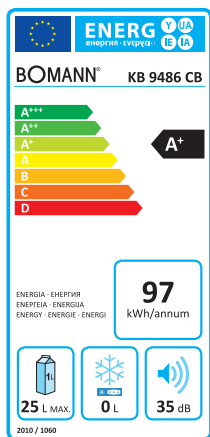

A++

Cool box
KB 9487 CB

- Suitable for cooling and warming
 - Perfect for camping, travel and shopping
 - Capacity (gross capacity): ca. 30 litre max.
 - Even cooling by integrated fan
 - Powerful, maintenance-free Peltier cooling/heating system
 - Energie saving function
 - Double walled plastic casing with high quality isolation
 - Special sealing rubber in the lid reduces condensation
 - Control lights for cooling and warming function
 - Foldable handle
 - Removable lid
 - Cable storage compartment
 - Accessory: 12 V connecting cable, 230 V connecting cable
- Power supply:
- Mains adapter connection: DC 12 V, 40/48 W
 - Mains adapter connection: AC 220–240 V, ~ 50/60 Hz, 52/58 W, 8 W (ECO mode)
- WxHxD approx. 405 x 435 x 300 mm
- Energy class: A++



For all standard 0.75 / 1.0 / 1.5-litre bottles

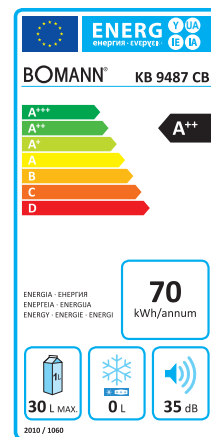

Art. no. 694 861
EAN 4 004 470 948 615

PU 1



Art. no. 694 871
EAN 4 004 470 948 714

PU 1





A

Wine cooler KSW 344

- Bottle capacity: 16 at 0.75 litres
- Net capacity: 46 litres
- Control panel with LED-display (blue illuminated)
- Electronical temperature setting and -control
- Eco-friendly, without coolant

General

- Wine storage cabinet
- Thermoelectric cooling
- Climate class N (+16 °C to +32 °C)
- Low-noise 43 dBA, without vibration
- Without compressor

Features

- Digital temperature settings and display (blue illuminated)
- Temperature settings from +11 °C to +18 °C, max. 14 °C below ambient temperature
- LED interior light (separate switchable)
- 3 removable shelves made of chrome (W 35.0 x D 26.5 cm)
- Double pane door with recessed handle
- Housing black color, door frame in silver color
- Adjustable feet
- 230 V~, 70 W
- W x H x D approx. 420 x 520 x 480 mm



B

Wine cooler KSW 345

- Bottle capacity: 18 at 0.75 litres
- Net capacity: 54 litres
- Control panel with LED-display (blue illuminated)
- Electronical temperature setting and -control
- Eco-friendly, without coolant

General

- Wine storage cabinet
- Thermoelectric cooling
- Climate class N (+16 °C to +32 °C)
- Low-noise 39 dBA, without vibration
- Without compressor

Features

- Digital temperature settings and display (blue illuminated)
- Temperature settings from +11 °C to +18 °C, max. 14 °C below ambient temperature
- LED interior light (separate switchable)
- 5 removable shelves made of chrome (W 27.5 x D 26.5 cm)
- Double pane door with recessed handle
- Housing black color, door frame in silver color
- Adjustable feet
- 230 V~, Connection power: 70 W
- W x H x D approx. 345 x 636 x 515 mm





100

**Replacement bottle/
Replacemant jars**

**Replacement bottle for
Smoothie maker SM 386 CB**

Art. no. 264 559
EAN 4006 160 645 590 PU 6

**Replacement jars for
Yoghurt-Maker JM 1025 CB**

Art. no. 251 125
EAN 4006 160 511 253 PU 4

Replacement cartridges

**Replacement cartridges for
DBS 778 CB, DBS 783 CB**

Art. no. 8 934 610
EAN 4006 160 632 583 PU 3

**Replacement cartridges for
DBS 792 CB, DBS 1793**

Art. no. 8 936 110
EAN 4006 160 632 606 PU 3

**Spare rolls
for bag sealer**

**Spare rolls for
FS3261**

Art. no.: 8 900 216
EAN 4 006 160 900 217 PU 10



You will find other accessory articles under www.bomann.de

Dust bags

| Vacuum cleaners | Article no. | EAN no. | Bomann type | Swirl type |
|---|-------------|-------------------|-------------|------------|
| BS 902 CB | 282 193 | 4 004 470 821 932 | SSB 98 | Y 98 |
| BS 911 CB | 282 047 | 4 006 160 820 478 | SSB 101 | Y 05 |
| CB 925 | 309 250 | 4 004 470 309 256 | B 45 | Y 101 |
| CB 917 / CB 918 / CB 929 | 282 049 | 4 006 160 820 492 | SSB 104 | Y 104 |
| CB 940 | 282 047 | 4 006 160 820 478 | SSB 101 | Y 93 |
| CB 941 | 309 410 | 4 004 470 309 416 | B 49 | Y 101 |
| CB 942 | 282 047 | 4 006 160 820 478 | SSB 101 | Y 101 |
| CB 946 | 282 193 | 4 006 160 821 932 | B 52/SSB 98 | Y 98 |
| CB 948 | 282 047 | 4 006 160 820 478 | SSB 101 | Y 101 |
| CB 949 | 282 047 | 4 006 160 820 478 | SSB 101 | Y 05 |
| CB 950 | 282 207 | 4 006 160 822 076 | SSB 30 | Y 30 |
| CB 952 / CB 953 | 282 049 | 4 006 160 820 492 | SSB 104 | Y 104 |
| CB 957 | 282 047 | 4 006 160 820 478 | SSB 101 | Y 101 |
| BS 961 CB | 282 047 | 4 006 160 820 478 | SSB 101 | Y 101 |
| CB 962 | 282 049 | 4 006 160 820 492 | SSB 104 | Y 104 |
| CB 965 | 282 047 | 4 006 160 820 478 | SSB 101 | Y 93 |
| CB 966 | 282 047 | 4 006 160 820 478 | SSB 101 | Y 05 |
| BS 968 CB | 282 193 | 4 006 160 821 932 | SSB 98 | Y 298 |
| BS 973 CB / BS 986 CB | 282 193 | 4 006 160 821 932 | SSB 98 | Y 298 |
| BS 974 CB | 282 193 | 4 006 160 821 932 | SSB 98 | Y 298 |
| BS 976 CB | – | – | – | Y 293 |
| BS 980 CB | 282 047 | 4 006 160 820 478 | SSB 101 | Y 50 |
| BS 981 CB | – | – | – | R 23 |
| BSS 982 CB | 8126102 | – | BSS 1261 | R 23 |
| BS 985 CB / BS 988 CB | 282 047 | 4 006 160 820 478 | SSB 101 | Y 93 |
| BS 987 CB | 282 047 | 4 006 160 820 478 | SSB 101 | Y 101 |
| BS 989 CB / BS 9014 CB / BS 9019 CB | 282 193 | 4 006 160 821 932 | SSB 98 | Y 98 |
| CB 991 | 282 047 | 4 006 160 820 478 | SSB 101 | Y 05 |
| CB 992 | 282 193 | 4 006 160 821 932 | SSB 98 | Y 98 |
| CB 993 | 282 207 | 4 006 160 822 076 | SSB 30 | Y 230 |
| BS 9010 CB / BS 9011 CB / BS 9015 CB / BS 9020 CB | 282 047 | 4 006 160 820 478 | SSB 101 | – |



Filter-sets

| Vacuum cleaners | Article no. | EAN no. | Bomann type |
|-----------------|-------------|-------------------|-------------------|
| BS 912 CB | 8912800 | – | Filterset BS 1280 |
| CB 954 | 282 840 | 4 006 160 828 405 | Filterset BS 1228 |
| CB 955 | 612 290 | 4 006 160 122 909 | Filterset BS 1229 |
| CB 956 | 282 862 | 4 006 160 828 627 | Filterset BS 1236 |
| BS 958 CB | 282 918 | 4 006 160 829 181 | Filterset BS 1273 |
| CB 964 | 282 886 | 4 006 160 828 863 | Filterset BS 1240 |
| BS 970 CB | 271 576 | 4 006 160 715 767 | Filterset BS 1247 |
| BS 971 CB | 282 906 | 4 006 160 829 068 | Filterset BS 1248 |
| BS 972 CB | 282 907 | 4 006 160 829 075 | Filterset BS 1249 |
| BS 975 CB | 282 914 | 4 006 160 829 143 | Filterset BS 1253 |
| BS 979 CB | 271 596 | 4 006 160 715 965 | Filterset BS 1256 |
| BS 983 CB | 282 907 | 4 006 160 829 075 | Filterset BS 1249 |
| BS 984 CB | 271 575 | 4 006 160 715 750 | Filterset BS 1255 |
| CB 997 | 282 850 | 4 006 160 828 504 | Filterset BS 1234 |



HEPA-filter

| Vacuum cleaners | Article no. | EAN no. | Bomann type |
|-----------------|-------------|-------------------|----------------|
| CB 939 | 209 390 | 4 004 170 093 905 | – |
| CB 950 | 282 203 | 4 006 160 822 038 | Filter BS 1224 |

TECHNICAL DATA FOR VACUUM CLEANERS Commission Delegated Regulation (EU) No. 665/2013

| Bomann | | | | | | | |
|---|--------------|------------|------------|------------|------------|------------|------------|
| Model | | BS 9010 CB | BS 9014 CB | BS 9015 CB | BS 9018 CB | BS 9019 CB | BS 9020 CB |
| Energy efficiency class ¹⁾ | | A | A | A | A | A | A |
| Energy consumption | | | | | | | |
| Annual energy consumption ²⁾ | kWh/year | 26.5 | 27.0 | 26.1 | 26.7 | 26.7 | 24.6 |
| Cleaning performance class | | | | | | | |
| Carpet cleaning performance class | | D | F | E | E | D | D |
| Hard floor cleaning performance class | | B | B | B | B | B | E |
| Dust re-emission class | | C | F | B | C | F | G |
| Sound power level | dB(A) re 1pW | 81 | 82 | 82 | 76 | 82 | 76 |
| Rated input power | W | 800 | 800 | 700 | 700 | 700 | 700 |

| Bomann | | | | | | | |
|---|--------------|------------|------------|------------|------------|--|--|
| Model | | BS 9021 CB | BS 9022 CB | BS 9027 CB | BS 1948 CB | | |
| Energy efficiency class ¹⁾ | | A | A | A | A | | |
| Energy consumption | | | | | | | |
| Annual energy consumption ²⁾ | kWh/year | 27.7 | 27.0 | 28.0 | 25.0 | | |
| Cleaning performance class | | | | | | | |
| Carpet cleaning performance class | | E | D | E | E | | |
| Hard floor cleaning performance class | | A | A | D | B | | |
| Dust re-emission class | | G | G | G | F | | |
| Sound power level | dB(A) re 1pW | 88 | 83 | 85 | 80 | | |
| Rated input power | W | 700 | 700 | 700 | 600 | | |

¹⁾ A (highest efficiency) to G (lowest efficiency).

²⁾ Indicative annual energy consumption (kWh per year), based on 50 cleaning tasks.
Actual annual energy consumption will depend on how the appliance is used.

The device meets the European standards and directives in the current version at delivery:

- Low Voltage Directive (LVD) 2006/95/EC
- Electromagnetic Compatibility (EMC) Legislation Directive 2004/108/EC
- Ecodesign requirements for vacuum cleaners COMMISSION REGULATION (EU) No 666/2013

TECHNICAL DATA FOR HOUSEHOLD REFRIGERATORS Commission Delegated Regulation (EU) No. 1060/2010

| Bomann | | | | | |
|---|--------------|------------|------------|---------|---------|
| Model | | KB 9486 CB | KB 9487 CB | KSW 344 | KSW 345 |
| Category ¹⁾ | | 10 | 10 | 2 | 2 |
| Energy efficiency class ²⁾ A+++ (highest efficiency) to G (lowest efficiency) | | A+ | A++ | A | B |
| Consumption data | | | | | |
| Annual energy consumption ³⁾ | kWh | 97 | 70 | 131 | 189 |
| Net capacity cooling total | l | 25 | 30 | 46 | 54 |
| Net capacity freezing | l | - | - | - | - |
| Star rating ⁴⁾ | | - | - | - | - |
| Frost-free | | - | - | - | - |
| Temperature rise time | h | - | - | - | - |
| Freezing capacity | kg/ 24 h | - | - | - | - |
| Climate class ⁵⁾ | | SN/N | SN/N | N | N |
| Noise level | dB(A) re 1pW | 35 | 35 | 43 | 39 |
| Design | | mobile | mobile | - | - |

¹⁾ Category: 1 = Refrigerator with one or more fresh-food storage compartments, 2 = Refrigerator-cellar, Cellar and Wine storage appliances, 3 = Refrigerator-chiller and Refrigerator with a 0-star compartment, 4 = Refrigerator with a one-star compartment, 5 = Refrigerator with a two-star compartment, 6 = Refrigerator with a three-star compartment, 7 = Refrigerator-freezer, 8 = Upright freezer, 9 = Chest freezer, 10 = Multi-use and other refrigerating appliances.

²⁾ A+++ (highest efficiency) to G (lowest efficiency).

³⁾ Annual energy consumption „XYZ“ kWh per year based on standard test results for 24 h. Actual energy consumption will depend on how the appliance is used and where is located.

⁴⁾ * = compartment: a frozen-food storage compartment in which the temperature is not warmer than -6°C.

*** = compartment: a frozen-food storage compartment in which the temperature is not warmer than -18°C.

(*)*** = food freezer compartment in which the temperature is not warmer than -18°C and a minimum freezing capacity in 24 h.

⁵⁾ Climate class SN: ambient temperature of +10°C up to +32°C. Climate class N: ambient temperature of +16°C up to +32°C. Climate class ST: ambient temperature of +16°C up to +38°C. Climate class T: ambient temperature of +16°C up to +43°C.









Headquarter



Logistic Center (approx. 60.000 m²)



Showroom



Quality assurance

BOMANN®

C. Bomann GmbH
Heinrich-Horten-Straße 17
47906 Kempen
Germany

Telephone: +49 2152 8998-0
Telefax: +49 2152 8998-911

mail@bomann.de
www.bomann.de