

BOMANN®

Home Appliances 2016



CONTENT



Coffee machines	15
Coffee grinder	19
Espresso machine	19
Kettle	21
Milk frother	20
Tea/coffee station	26
Water kettle	25



Automatic toasters	26
Crêpe maker	31
Donut maker	32
Egg boiler	36
Ice cream cone maker	31
Ice cube maker	35
Muffin maker	32
Multigrill	34
Pepper/salt mill	36
Sandwich toaster	32
Soft ice maker	35
Waffle maker	30
Yogurt maker	35



Automatic juicer	55
Bag sealer	57
Citrus fruit squeezer	55
Deep fat fryers	57
Fondue deep fat pan	57
Food dryer	56
Food processor	44
Food slicer	36

Hand blender	37
Hand blender set	38
Hand mixer	41
Hand mixer set	43
Kitchen scales	56
Kneading/stirring machine	44
Kneading/stirring machine set	46
Mincer	52
Multi express	39
Multi chopper	40
Smoothie maker	54
Universal mixer	53



Bread maker	59
Barbecue standing grill	65
Barbecue table grill	65
Built-in microwaves with grill	74
Contact grill	61
Convection oven	67
Fondue set	64
Gas grill	66
Hot dog maker	60
Hotplates	75
Induction hot plates	76
Microwaves	70
Mini kitchen	69
Mini oven	67
Multi oven	68
Multi pizza oven	68
Raclette grills	64
Rice boiler	59
Steam cooker	60
Party pans	62



Steam irons	78
Mini-washing machine	81
Steam ironing unit	80
Textile cleaner	77
Fabric steamer	81



Battery vacuum cleaner	84
Floor vacuum cleaner	86
Hand vacuum cleaner	85
High pressure cleaner	83
Steam cleaner	82
Steam mop	83
Wet and dry cleaner	90
Window cleaner	84



Bathroom scales	91
Foot massage equipment	91
Hair and beard trimmer	92
Hair crimper / hot air styler	93
Hair dryer	94
Nose and ear hair remover	92



Accessoires	101
Air dehumidifier	98
Cool boxes	99
Ventilators	96
Wine cooler	100
Fan heater	97



Universal mixer
UM 1569 CB => page 53

Kettle
WK 1566 CB => page 23



Automatic toaster
TA 1567 CB => page 28



Multi purpose mixer
MZ 1568 CB => page 41



Coffee machine
KA 1565 CB => page 17



Colour up



Hand blender
SM 384 CB => page 37



Multi chopper
MZ 449 CB => page 40



Hand mixer
HM 350 CB => page 42





Glass kitchen scale
KW 1515 CB => page 55

Smoothie maker
SM 386 CB => page 54



*your
life*



Kettle
WK 5011 CB => page 21





Coffee machine KA 1575 CB

- For 8–10 cups of coffee (approx. 1,25 l)
- Anti-drip protection
- Swivel filter
- On/off switch with control lamp (blue illuminated)
- Water level indicator
- Heating plate with automatic switch-off
- 230 V, 50 Hz, 870 W max.



Automatic toaster TA 1577 CB

- Compact 2-slice toaster
- Cool touch housing
- Bun warmer (removable)
- Defrost/reheat/quick-stop function
- Continuously adjustable browning
- 3 control lamps (blue illuminated)
- Automatic/manual switch-off
- Crumb drawer
- Cord storage
- 230 V, 50 Hz, 870 W max.

Kettle WK 1576 CB

- Max. capacity 1.7 litre
- Simple handling due to cable-free technology – easy to pour in and out
- Safety lid
- Lime filter (removable)
- On/off switch (illuminated in blue)
- Stainless steel heating element
- Automatic/manual switch-off
- External water level indicator
- Base station with cord storage
- Evaporation/overheating protection
- 230 V, 50 Hz, 2200 W



Coffee machine

KA 1575 CB

- For 8–10 cups of coffee (approx. 1,25 l)
- Anti-drip protection
- Swivel filter
- On/off switch with control lamp (blue illuminated)
- Water level indicator
- Heating plate with automatic switch-off
- 230 V, 50 Hz, 870 W max.

Automatic toaster

TA 1577 CB

- Compact 2-slice toaster
- Cool touch housing
- Bun warmer (removable)
- Defrost/reheat/quick-stop function
- Continuously adjustable browning
- 3 control lamps (blue illuminated)
- Automatic/manual switch-off
- Crumb drawer
- Cord storage
- 230 V, 50 Hz, 870 W max.

Kettle

WK 1576 CB

- Max. capacity 1.7 litre
- Simple handling due to cable-free technology – easy to pour in and out
- Safety lid
- Lime filter (removable)
- On/off switch (blue illuminated)
- Stainless steel heating element
- Automatic/manual switch-off
- External water level indicator
- Base station with cord storage
- Evaporation/overheating protection
- 230 V, 50 Hz, 2200 W



ST/WA 1364 CB



ST 1363 CB



ST 1372 CB



TA 1371 CB



WA 1365 CB



KA 1369 CB



KA 1370 CB



KA 1367 CB





UM 1354 CB

AE 1917 CB



ESTATE



WKS 1356 CB



KA 1360 CB



WKS 1361 CB



KA 1341 CB





Coffee machine KA 1571 CB

- For 8–10 cups of coffee (approx. 1,25 l)
- Anti-drip protection
- Swivel filter
- On/off switch with control lamp
- Water level indicator
- Heating plate with automatic switch-off
- 230 V, 50 Hz, 870 W max.

Automatic toaster TA 1573 CB

- Compact 2-slice toaster
- Cool touch housing
- Bun warmer (removable)
- Defrost/reheat/quick-stop function
- Continuously adjustable thermostat
- 3 control lamps
- Automatic/manual switch-off
- Crumb drawer
- Cord storage
- 230 V, 50 Hz, 600–700 W. max.

Kettle WK 1572 CB

- Max. capacity 1.7 litre
- Simple handling due to cable free technology – easy to pour in and out
- Safety lid
- Lime filter (removable)
- On/off switch (illuminated)
- Stainless steel heating element
- Automatic/manual switch-off
- External water level indicator
- Base station with cord storage
- Evaporation/overheating protection
- 230 V, 50 Hz, 2200 W

3in1

Coffee machine
Automatic toaster
Kettle



Coffee machine KA 1501 CB

- For 8-10 cups of coffee
- Anti-drip protection
- On/off switch with control lamp
- Swivel filter
- Water level indicator
- Heating plate with automatic switch-off
- 230 V, 50 Hz, 870 W max.
- WxHxD approx. 210 x 300 x 220 mm

Kettle WK 1502 CB

- Max. capacity 1,7 litre
- Cordless, for easy using
- Nylon filter (removable)
- On/off switch with control lamp
- Automatic/manual switch-off
- 2 external water level indicators
- Evaporation/overheating protection
- 230 V, 50 Hz, 2200 W max.
- WxHxD approx. 250 x 265 x 135 mm

Automatic toaster TA 1503 CB

- 2-slice toaster
- Cool touch housing
- Continuously adjustable thermostat
- Defrost/reheat/quick-stop function
- Lift function
- Crumb drawer (removable)
- Bun warmer (integrated)
- Base station with cord storage
- 230 V, 50 Hz, 800 W
- WxHxD approx. 275 x 180 x 180 mm

FS 1500 CB Breakfast-Set black

● Art. no. 615 001
EAN 4 004 470 150 018

PU 4



- Sales Packaging
WxHxD approx. 515 x 312 x 240 mm



Coffee machine
KA 1580 CB

- For 8-10 cups of coffee (approx. 1.25 l)
- Stainless steel insert
- Anti-drip protection
- Filter holder (removable)
- On/off switch with control lamp (blue illuminated)
- Water level indicator
- Heating plate with automatic switch-off
- 230 V, 50 Hz, 1000 W



Automatic toaster
TA 1582 CB

- 2-slice toaster
- Stainless steel insert
- Cool touch housing
- Bun warmer (integrated)
- Defrost, reheat, quick-stop function
- Continuously adjustable thermostat
- 3 control lamps (blue illuminated)
- Centring function
- Automatic/manual switch-off
- Crumb drawer
- Cord storage
- 230 V, 50 Hz, 850 W



Kettle
WKS 1581 CB

- Max. capacity 1.5 litre
- Stainless steel insert
- Simple handling due to cable-free technology – easy to pour in and out
- 360° connector
- Locked safety hinged lid with one-handed operation
- Lime filter (removable)
- On/off switch (blue illuminated)
- Concealed stainless steel heating element
- Automatic/manual switch-off
- 2 external water level indicators
- Base station with cord storage
- Evaporation/overheating protection
- 230 V, 50 Hz, 2200 W





1-cup coffee machine
KA 180 CB

- „Coffee to go“ – simple, quick, and fresh, with the familiar taste of an aromatic filter coffee
- Ideal for camping, in the office, at home or on the way
- Incl. thermo stainless steel cup with drink opening and heat insulated aroma seal lid
- 300 ml capacity
- Permanent nylon filter (removable)
- Cup fits virtually all standard cup holders
- Rubberised „Soft Touch“ handle
- On/off switch
- Control lamp
- 230 V, 50 Hz, 420 W
- W x H x D approx. 165 x 160 x 245 mm



NEW! 1 cup coffee machine
KA 201 CB

- 1 cup coffee machine for filter coffee
- Space-saving design (ideal when out and about)
- Includes one ceramic cup
- Permanent nylon filter (removable)
- On/off switch with control lamp
- Automatic power off
- Nonslip tray (removable)
- 220–240 V, 50 Hz, 270–330 W
- W x H x D approx. 130 x 175 x 155 mm



Coffee machine
KA 165 CB

- For 10-12 cups of coffee (approx. 1.5 litre)
- Anti-drip protection
- Swivel filter
- On/off switch with control lamp
- Water level indicator
- Heating plate with automatic switch-off
- Transparent water container
- Evaporation protection
- 230 V, 50 Hz, 800 W
- W x H x D approx. 165 x 285 x 225 mm



Coffee machine
KA 1575 CB

- For 8-10 cups of coffee (approx. 1.25 litre)
- Anti-drip protection
- Swivel filter
- On/off switch with control lamp (blue illuminated)
- Water level indicator
- Heating plate with automatic switch-off
- 230 V, 50 Hz, 870 W max.
- WxHxD approx. 165 x 300 x 250 mm

Coffee machine
KA 1571 CB

- For 8-10 cups of coffee (approx. 1.25 litre)
- Anti-drip protection
- Swivel filter
- On/off switch with control lamp
- Water level indicator
- Heating plate with automatic switch-off
- 230 V, 50 Hz, 870 W max.
- WxHxD approx. 165 x 300 x 250 mm

Coffee machine
KA 183 CB

- For 12-14 cups of coffee (approx. 1.5 litre)
- Anti-drip protection
- Filter holder (removable)
- On/off switch (illuminated)
- Water level indicator
- Heating plate with automatic switch-off
- Cord storage
- 230 V, 50 Hz, 900 W
- WxHxD approx. 190 x 330 x 205 mm



Can also be combined as a suitable breakfast set



Can also be combined as a suitable breakfast set

● Art. no. 615 750
EAN 4 004 470 157 505 PU 6
● Art. no. 615 751
EAN 4 004 470 157 512 PU 6



● Art. no. 615 711
EAN 4 004 470 157 116 PU 6



● Art. no. 601 830
EAN 4 004 470 018 301 PU 6
● Art. no. 601 833
EAN 4 004 470 018 332 PU 6





Coffee machine
KA 1580 CB

- For 8-10 cups of coffee (approx. 1.25 litre)
- Stainless steel insert
- Anti-drip protection
- Filter holder (removable)
- On/off switch with control lamp (blue illuminated)
- Water level indicator
- Heating plate with automatic switch-off
- 230 V, 50 Hz, 1000 W
- WxHxD approx. 185 x 310 x 260 mm

Coffee machine
KA 1369 CB

- For 12-14 cups of coffee (approx. 1.5 litre)
- High-quality stainless steel application
- Anti-drip protection
- Filter holder (removable)
- On/off switch with control lamp (blue illuminated)
- Water level indicator
- Heating plate with automatic switch-off
- 230 V, 50 Hz, 900 W
- WxHxD approx. 180 x 325 x 260 cm

Coffee machine
KA 1565 CB

- For 8-10 cups of coffee (approx. 1.2 litre)
- Stainless steel insert and lid
- Anti-drip protection
- Filter holder (removable)
- On/off switch with control lamp
- Water level indicator
- Heating plate with automatic switch-off
- 230 V, 50 Hz, 900 W
- WxHxD approx. 195 x 335 x 220 mm



Can also be combined as a suitable breakfast set



Can also be combined as a suitable kitchen set

● **Art. no. 615 801**
EAN 4 004 470 158 014 PU 6



● **Art. no. 613 691**
EAN 4 004 470 136 913 PU 4



● **Art. no. 615 651**
EAN 4 004 470 156 515 PU 4
● **Art. no. 615 654**
EAN 4 004 470 156 546 PU 4





18

Coffee machine KA 1367 CB

- For 15 cups of coffee (approx. 1.7 litre)
- Stainless steel front
- Programmable 24-hour LCD digital timer
- Anti-drip protection
- Filter holder (removable)
- 4 control buttons (illuminated)
- Heating plate with automatic switch-off
- Water level indicator
- 230 V, 50 Hz, 1000 W
- W x H x D approx. 220 x 375 x 240 mm



Programmable 24-hour LCD digital timer

Thermo coffee machine KA 168 CB

- For 8-10 cups of coffee (approx. 1.0 litre)
- Thermo jug (double-walled)
- Anti-drip protection
- Filter holder (removable)
- On/off switch with control lamp
- Automatic power off
- Water level indicator
- 220-240 V, 50 Hz, 870 W max.
- W x H x D approx. 185 x 340 x 210 mm

Thermo coffee machine KA 1370 CB

- For 8-10 cups of coffee (approx. 1.2 l)
- Stainless steel thermo jug (double-walled) with aroma seal – drinks remain hot for longer
- High-quality stainless steel application
- Anti-drip protection
- Filter holder (removable)
- On/off switch with control lamp (blue illuminated)
- Automatic power off
- Water level indicator
- 220-240 V, 50 Hz, 800 W
- W x H x D approx. 180 x 325 x 260 cm



Double-walled thermo jug with aroma seal – drinks remain hot for longer

● Art. no. 613 671
EAN 4 004 470 136 715 PU 4



● Art. no. 601 680
EAN 4 004 470 016 802 PU 6
● Art. no. 601 683
EAN 4 004 470 016 871 PU 6



● Art. no. 613 701
EAN 4 004 470 137 019 PU 4





Stainless steel housing

Espresso machine
ES 184 CB

- Espresso and cappuccino pump machine
- Swivelling stainless steel steam nozzle with foaming and hot water function
- Steam volume steplessly adjustable
- Steam nozzle tip removable for easy cleaning
- Cup warming function with aluminum insert
- Constant pump pressure (15 bar)
- 1.5 litre water tank (removable)
- External water level indicator
- Collection cup with aluminum drip grid (removable)
- 2 control lamps
- Automatic power off
- Ready status indicator
- Accessories: 2 filter holders (1 and 2 cups), coffee measure, tamper
- 230 V, 50 Hz, 1050 W
- WxHxD approx. 185 x 290 x 215 mm

Coffee grinder
KSW 445 CB

- Electric coffee mill with beater
- Stainless steel beater blade
- Stainless steel bean container, hygienic and with aroma protection
- Transparent lid
- Capacity 40 g – for 20 cups of coffee
- With 120 watt motor
- Safety circuit – operation only possible with lid in place
- Safety pushbutton also for pulsed operation
- Degree of grinding can be selected by the length of operation
- Cord storage
- 230 V, 50 Hz, 120 W
- WxHxD approx. 100x200x100 mm

Coffee grinder
KSW 446 CB

- Electric coffee mill with beater
- Stainless steel beater blade
- Stainless steel bean container, hygienic and with aroma protection
- Transparent lid
- Capacity 40 g – for 20 cups of coffee
- With 120 watt motor
- Safety circuit – operation only possible with lid in place
- Safety pushbutton also for pulsed operation
- Degree of grinding can be selected by the length of operation
- Cord storage
- 230 V, 50 Hz, 120 W
- WxHxD approx. 100x200x100 mm



Cup warming function



Cold and warm
foaming function

ESPUCCINO 

Glass milk frother MS 376 CB

- No preheating of the milk thanks to the integrated heating function
 - Creates foamy milk in seconds
 - Also suitable for hot and cold chocolate
 - Glass container (750 ml) with stainless steel handle
 - Amount of milk foam: approx. 300 ml
 - Simple handling due to cable-free technology, plug connection rotates through 360°
 - Electronic 3 function switch
 - Froth the milk warm
 - Froth the milk cold – ideal for iced coffee
 - Heat the milk
 - Built-in heating element
 - Automatic switch-off function
 - Incl. lid with splash guard function
 - Additional stirrer hot drinks without foaming (e.g. cacao)
 - Glass container and lid removable for easy cleaning
- 230 V, 50 Hz, 600 W
■ W x H x D approx. 120 x 180 x 175 mm

Milk frother MS 344 CB

- Creates foamy milk in seconds
 - Soft touch housing
 - Stainless steel whisk
 - Easy to clean
- Battery operation: 2 x 1,5 V AA/UM 3 (batteries not included)
■ W x H x D approx. 47 x 225 x 32 mm

Milk frother MS 3502

- Creates foamy milk in seconds
 - Easy handling due to cable-free technology
 - Stainless steel housing
 - Stainless steel frothing whisk
 - Including stainless steel stand and closure cap for practical and hygienic storage
 - LED control lamp (red illuminated)
 - Detachable stainless steel cap (lockable)
- Battery operation: 2x 1.5 V (AA) (batteries not included)
■ Length approx. 230 mm; Ø 32 mm



Promotional
Packaging

● Art. no. 603 760
EAN 4 004 470 036 855

PU 4



● Art. no. 603 441
EAN 4 004 470 034 417

PU 20



● Art. no. 261 674
EAN 4 004 470 616 743

PU 10





Kettle
WK 5024 CB

- Max. capacity 1.0 litre
 - Simple handling due to cable-free technology – easy to pour in and out
 - Safety hinged lid with single-handed operation
 - Lime filter (removable)
 - On/off switch (illuminated)
 - Stainless steel heating element
 - Automatic/manual switch-off
 - 2 external water level indicators
 - Rubber profile on the handle
 - Incl. base station
 - Evaporation/overheating protection
- 230 V, 50 Hz, 900 W
■ WxHxD approx. 185 x 220 x 115 mm

Kettle
WK 5011 CB

- Max. capacity 1.7 litre
 - Simple handling due to cable-free technology – easy to pour in and out
 - Safety hinged lid with single-handed operation
 - Lime filter (removable)
 - On/off switch (illuminated)
 - Stainless steel heating element
 - Automatic/manual switch-off
 - 2 external water level indicators
 - Rubber profile on the handle
 - Base station with cord storage
 - Evaporation/overheating protection
- 230 V, 50 Hz, 2200 W
■ WxHxD approx. 220 x 255 x 140 mm

Kettle
WK 5011 CB

- Max. capacity 1.7 litre
 - Simple handling due to cable-free technology – easy to pour in and out
 - Safety hinged lid with single-handed operation
 - Lime filter (removable)
 - On/off switch (illuminated)
 - Stainless steel heating element
 - Automatic/manual switch-off
 - 2 external water level indicators
 - Rubber profile on the handle
 - Base station with cord storage
 - Evaporation/overheating protection
- 230 V, 50 Hz, 2200 W
■ WxHxD approx. 220 x 255 x 140 mm



Can also be combined as a suitable kitchen set

- Art. no. 650 240
EAN 4 004 470 502 404 PU 6
- Art. no. 650 241
EAN 4 004 470 502 411 PU 6

- Art. no. 650 110
EAN 4 004 470 501 100 PU 6
- Art. no. 650 113
EAN 4 004 470 501 131 PU 6
- Art. no. 650 111
EAN 4 004 470 501 117 PU 6

- Art. no. 650 118
EAN 4 004 470 501 186 PU 6
- Art. no. 650 119
EAN 4 004 470 501 193 PU 6
- Art. no. 650 117
EAN 4 004 470 501 179 PU 6





Kettle
WK 1576 CB

- Max. capacity 1.7 litre
 - Simple handling due to cable-free technology – easy to pour in and out
 - Safety hinged lid
 - Lime filter (removable)
 - On/off switch (blue illuminated)
 - Stainless steel heating element
 - Automatic/manual switch-off
 - External water level indicator
 - Base station with cord storage
 - Evaporation/overheating protection
- 230, V, 50 Hz, 2200 W
■ WxHxD approx. 220 x 235 x 125 mm

Kettle
WK 1572 CB

- Max. capacity 1.7 litre
 - Simple handling due to cable-free technology – easy to pour in and out
 - Safety hinged lid
 - Lime filter (removable)
 - On/off switch (illuminated)
 - Stainless steel heating element
 - Automatic/manual switch-off
 - External water level indicator
 - Base station with cord storage
 - Evaporation/overheating protection
- 230, V, 50 Hz, 2200 W
■ WxHxD approx. 220 x 235 x 125 mm

Kettle
WK 5012 CB

- Max. capacity 1.8 litre
 - Simple handling due to cable-free technology – easy to pour in and out
 - 360° connector
 - Lockable safety hinged lid with single-handed operation
 - Lime filter (removable)
 - On/off switch (illuminated)
 - Concealed stainless steel heating element
 - Automatic/manual switch-off
 - 2 external water level indicators
 - Base station with cord storage
 - Overheating protection
- 230 V, 50 Hz, 2200 W
■ WxHxD approx. 225 x 255 x 150 mm



Can also be combined as a suitable breakfast set



Can also be combined as a suitable breakfast set

● Art. no. 615 760
EAN 4 004 470 157 604 PU 6
● Art. no. 615 761
EAN 4 004 470 157 611 PU 6



● Art. no. 615 721
EAN 4 004 470 157 215 PU 6



● Art. no. 650 120
EAN 4 004 470 501 209 PU 6
● Art. no. 650 123
EAN 4 004 470 501 216 PU 6





Stainless steel

Kettle
WKS 1581 CB

- Max. capacity 1.5 litre
 - Stainless steel insert
 - Simple handling due to cable-free technology – easy to pour in and out
 - 360° connector
 - Lockable safety hinged lid with single-handed operation
 - Lime filter (removable)
 - On/off switch (blue illuminated)
 - Concealed stainless steel heating element
 - Automatic/manual switch-off
 - 2 external water level indicators
 - Base station with cord storage
 - Evaporation/overheating protection
- 230 V, 50 Hz, 2200 W
■ W x H x D approx. 155 x 245 x 215 mm

Kettle
WK 1566 CB

- Max. capacity 1.7 litre
 - Simple handling due to cable-free technology – easy to pour in and out
 - 360° connector
 - Safety hinged lid with stainless steel insert and single-handed operation
 - Lime filter (removable)
 - On/off switch
 - Concealed stainless steel heating element
 - Automatic/manual switch-off
 - 2 external water level indicators (illuminated)
 - Base station with cord storage
 - Overheating protection
- 230 V, 50 Hz, 2200 W
■ W x H x D approx. 220 x 235 x 160 mm

NEW! **Travel kettle**
WKR 1162 CB

- Ideal when traveling and on the move
 - Max. capacity 0.5 litre
 - Stainless steel housing
 - Incl. 2 cups @ 170 ml, transport / travel bag and stainless steel spoon
 - Concealed stainless steel heating element
 - Control lamp
 - Automatic switch-off
 - Evaporation/overheating protection
- 110/230 V, 50 Hz, 1000 W
■ W x H x D approx. 160 x 170 x 105 mm



Can also be combined as a suitable breakfast set



Can also be combined as a suitable kitchen set



Incl. transport / travel bag



Incl. 2 cups à 170 ml + stainless steel spoon

● **Art. no. 615 811**
EAN 4 004 470 158 113 PU 6



● **Art. no. 615 661**
EAN 4 004 470 156 614 PU 4
● **Art. no. 615 664**
EAN 4 004 470 156 645 PU 4



● **Art. no. 611 621**
EAN 4 004 470 116 212 PU 6





Stainless steel

Stainless steel

Stainless steel

Kettle
WKS 1361 CB

- Max. capacity 1.0 litre
 - Stainless steel thermo housing
 - Simple handling due to cable-free technology – easy to pour in and out
 - 360° connector
 - Lockable safety hinged lid
 - Lime filter (removable)
 - On/off switch
 - Concealed stainless steel heating element
 - Automatic/manual switch-off
 - Water level indicator
 - Base station with cord storage
 - Evaporation/overheating protection
- 230 V, 50 Hz, 2200 W max.
■ W x H x D approx. 220 x 195 x 150 mm

Kettle
WKS 5010 CB

- Max. capacity 1.7 litre
 - Simple handling due to cable-free technology – easy to pour in and out
 - 360° connector
 - Lockable safety hinged lid
 - Lime filter (integrated)
 - On/off switch (illuminated)
 - Stainless steel body
 - Concealed stainless steel heating element
 - Automatic/manual switch-off
 - Water level indicator
 - Cord storage
 - Evaporation/overheating protection
- 220–240 V, 50 Hz, 2000–2400 W max.
■ W x H x D approx. 230 x 250 x 145 mm

Kettle
WKS 1356 CB

- Max. capacity 1.7 litre
 - Simple handling due to cable-free technology – easy to pour in and out
 - 360° connector
 - Lockable safety hinged lid
 - Lime filter (removable and washable)
 - On/off switch
 - Control lamp (blue illuminated)
 - Stainless steel thermo housing
 - Concealed stainless steel heating element
 - Automatic/manual switch-off
 - 2 external water level indicators
 - Base station with cord storage (stainless steel sheathed)
 - Evaporation/overheating protection
- 230 V, 50 Hz, 2200 W max.
■ W x H x D approx. 220 x 250 x 145 mm

● Art. no. 613 611
EAN 4 004 470 136 111 PU 6



● Art. no. 650 100
EAN 4 004 470 501 001 PU 6
● Art. no. 650 103
EAN 4 004 470 501 032 PU 6
● Art. no. 650 101
EAN 4 004 470 501 018 PU 6



● Art. no. 613 561
EAN 4 004 470 135 619 PU 6





Stainless steel



Stainless steel

Glass kettle
WK 5023 G CB**NEW!** Water kettle
WKS 5031 CB

- Max. capacity 1.8 litre
 - Simple handling due to cable-free technology – easy to pour in and out
 - 360° connector
 - Lime filter (removable, washable)
 - On/off switch (illuminated)
 - Concealed stainless steel heating element
 - Stainless steel water jug
 - Automatic/manual switch-off
 - External water level indicator
 - Base station with cord storage
 - Evaporation/overheating protection
- 230 V, 50 Hz, 1850–2200 W
■ WxHxD approx. 245 x 295 x 225 mm

Water kettle
WK 5025 CB

- Max. capacity 1.8 litre
 - Simple handling due to cable-free technology – easy to pour in and out
 - 360° connector
 - Lime filter (integrated)
 - On/off switch
 - Concealed stainless steel heating element
 - Stainless steel water jug
 - Automatic/manual switch-off
 - External water level indicator
 - Base station with cord storage
 - Evaporation/overheating protection
- 230 V, 50 Hz, 1800 W
■ WxHxD approx. 200 x 285 x 230 mm

- Max. capacity 1.7 litre
 - Glass/stainless steel housing
 - Water container made of heat resistant safety glass
 - Simple handling due to cable-free technology – easy to pour in and out
 - 360° connector
 - On/off switch
 - Concealed stainless steel heating element
 - Automatic/manual switch-off
 - External water level indicator
 - Base station with cord storage (stainless steel sheathed)
 - Evaporation/overheating protection
- 220–240 V, 50 Hz, 1850–2200 W max
■ WxHxD approx. 220 x 240 x 150 mm



External water level indicator



External water level indicator

● Art. no. 650 316
EAN 4 004 470 503 166 PU 4
● Art. no. 650 311
EAN 4 004 470 503 111 PU 4

● Art. no. 650 251
EAN 4 004 470 502 510 PU 4

● Art. no. 650 231
EAN 4 004 470 502 312 PU 4





3in1



Tea/coffee station TKS 1311 CB

3 in 1 – tea/coffee station with stainless steel water kettle and tea/coffee maker

Water kettle:

- Max. capacity 1.7 litre
- Stainless steel water kettle with integrated heating element
- Simple handling due to cable-free technology – easy to pour in and out
- 360° connector
- On/off switch
- Lockable safety hinged lid
- Lime filter (integrated)
- Automatic/manual switch-off
- Water level indicator
- Evaporation/overheating protection

Glass jug:

- For tea and coffee making
- Max. capacity 1.2 litre
- Heat-resistant glass
- Stainless steel tea filter (removable)

Base:

- Keep warm function
 - Heating plate (non-stick coated)
 - On/off switch (illuminated)
 - Heat insulated handles
 - Non-slip stand
- 220–240 V, 50 Hz, 2000–2250 W max.
 - WxHxD approx. 410 x 300 x 180 mm

Automatic toaster TA 246 CB

- Compact 2-slice toaster
 - Cool touch housing
 - Bun warmer (integrated)
 - Defrost/reheat/quick-stop function
 - Continuously adjustable thermostat
 - 2 control lamps
 - Automatic/manual switch-off
 - Crumb drawer
 - Base station with cord storage
- 230 V, 50 Hz, 700 W. max.
 - WxHxD approx. 285 x 240 x 165 mm

● Art. no. 613 110
EAN 4 004 470 131 109 PU 2



● Art. no. 602 460
EAN 4 004 470 024 609 PU 6
● Art. no. 602 463
EAN 4 004 470 024 630 PU 6





Automatic toaster
TA 1577 CB

- Compact 2-slice toaster
 - Cool touch housing
 - Bun warmer (removable)
 - Defrost/reheat/quick-stop function
 - Continuously adjustable browning
 - 3 control lamps (blue illuminated)
 - Automatic/manual switch-off
 - Crumb drawer
 - Cord storage
- 230 V, 50 Hz, 870 W max.
 - WxHxD approx. 260 x 170 x 145 mm



Automatic toaster
TA 1573 CB

- Compact 2-slice toaster
 - Cool touch housing
 - Bun warmer (removable)
 - Defrost/reheat/quick-stop function
 - Continuously adjustable thermostat
 - 3 control lamps
 - Automatic/manual switch-off
 - Crumb drawer
 - Cord storage
- 230 V, 50 Hz, 600–700 W. max.
 - WxHxD approx. 260 x 170 x 145 mm



Can also be combined as a suitable breakfast set



Can also be combined as a suitable breakfast set

● **Art. no. 615 770**
EAN 4 004 470 157 703 PU 6
● **Art. no. 615 771**
EAN 4 004 470 157 710 PU 6



● **Art. no. 615 732**
EAN 4 004 470 157 321 PU 6





Automatic toaster
TA 1582 CB

- 2-slice toaster
 - Stainless steel insert
 - Cool touch housing
 - Bun warmer (integrated)
 - Defrost/reheat/quick-stop function
 - Continuously adjustable thermostat
 - 3 control lamps (blue illuminated)
 - Centring function
 - Automatic/manual switch-off
 - Crumb drawer
 - Cord storage
- 230 V, 50 Hz, 850 W
 - WxHxD approx. 300 x 175 x 170 mm

Automatic toaster
TA 1567 CB

- 2-slice toaster
 - Stainless steel insert
 - Cool touch housing
 - Bun warmer (removable)
 - Defrost/reheat/quick-stop function
 - Continuously adjustable thermostat
 - 3 control lamps
 - Centring function
 - Automatic/manual switch-off
 - Crumb drawer
 - Cord storage
- 230 V, 50 Hz, 800 W
 - WxHxD approx. 285 x 160 x 170 mm



Can also be combined as a suitable breakfast set



Can also be combined as a kitchen breakfast set

● **Art. no. 615 821**
EAN 4 004 470 158 212 PU 6



● **Art. no. 615 671**
EAN 4 004 470 156 713 PU 4
● **Art. no. 615 674**
EAN 4 004 470 156 744 PU 4





 Stainless steel housing

NEW! Automatic toaster
TA 1371 CB

- 2-slice toaster
 - Stainless steel housing
 - Bun warmer (removable)
 - Defrost/reheat/quick-stop function (blue illuminated)
 - Continuously adjustable thermostat
 - Centring function
 - Automatic/manual switch-off
 - Crumb drawer
 - Cord storage
- 220–240 V, 50/60 Hz, 750–850 W
 - W x H x D approx. 270 x 180 x 150 mm

Automatic toaster
TA 245 CB

- 4-slice long-slot toaster
 - Heat-insulated cool touch housing
 - Bun warmer (removable)
 - Defrost/reheat/quick-stop function
 - Continuously adjustable browning
 - 3 LED control lamps
 - Automatic switch-off
 - Crumb drawer
 - Cord storage
- 230 V, 50 Hz, 1400 W
 - W x H x D approx. 375 x 175 x 165 mm

29



Defrost/reheat/
quick-stop function
(blue illuminated)

● Art. no. 613 711
EAN 4 004 470 137 118

PU 4



● Art. no. 602 450
EAN 4 004 470 024 500

PU 6





30

Waffle maker
WA 5018 CB

- Large baking plates: approx. Ø 18 cm (non-stick coated)
- Heat insulated handle
- Continuously adjustable browning level
- 2 control lamps for power and heating (baking lights)
- High stability through rubberized feet
- Overheating protection

- 220–240 V, 50 Hz, 1200 W
- WxHxD approx. 205 x 115 x 250 mm

Waffle maker
WA 1365 CB

- Stainless steel insert
- Large baking plates: approx. Ø 18 cm (non-stick coated)
- Heat insulated handle
- Continuously adjustable browning level
- 2 control lamps for power and heating (baking lights)
- Overheating protection

- 230 V, 50 Hz, 1000 Watt
- WxHxD approx. 260 x 100 x 260 mm



Stainless steel insert

● Art. no. 650 180
EAN 4 004 470 616 798 PU 6
● Art. no. 650 181
EAN 4 004 470 501 810 PU 6



● Art. no. 613 651
EAN 4 004 470 616 811 PU 4





Waffle maker
WA 5030 CB

- Stainless steel insert
- 2 large baking plates (non-stick coated)
- 2 waffles for each baking procedure
- Heat insulated handle
- Continuously adjustable browning level
- 2 control lamps for power and heating (baking lights)
- High stability through rubberized feet
- Overheating protection
- Cord storage
- 220–240 V, 50 Hz, 1200 W
- WxHxD approx. 350 x 105 x 230 mm

Ice cream cone maker
HA 5017 CB

- Large baking plate: approx. Ø 18 cm (non-stick coated)
- Heat insulated handle
- Continuously adjustable browning level
- 2 control lamps for power and heating (baking lights)
- High stability through rubberized feet
- Incl. squirrel cone
- Overheating protection
- 220-240 V, 50 Hz, 1200 W
- WxHxD approx. 205 x 115 x 250 mm

Crêpe maker
CM 2221 CB

- Large baking plate: approx. Ø 29 cm (non-stick coated)
- Paper-thin crêpes, quickly and easily prepared
- Heat-insulated plastic base
- Infinitely adjustable thermostat
- 2 control lamps for power and heating (baking lights)
- Base station with cord storage
- Incl. batter distributor
- 230 V, 50 Hz, 900 W
- WxHxD approx. 325 x 80 x 370 mm



Stainless steel insert



Incl. squirrel cone



Incl. batter distributor

● **Art. no. 650 301**
EAN 4 004 470 503 012

PU 4



● **Art. no. 650 171**
EAN 4 004 470 616 835

PU 6



● **Art. no. 622 211**
EAN 4 004 470 222 111

PU 4





32

Donut maker
DM 5021 CB

- For baking up to 7 bagels/donuts
- Baking surfaces non-stick coated
- Heat insulated handle
- 2 control lamps for power and heating (baking lights)
- Excellent stability through rubberized feet
- Overheating protection

- 230 V, 50 Hz, 900 W
- WxHxD approx. 225 x 115 x 225 mm

Muffin maker
MM 5020 CB

- For baking up to 7 muffins
- Muffin diameter approx. 4,5 cm
- Baking surfaces non-stick coated
- Heat insulated handle
- 2 control lamps for power and heating (baking lights)
- Excellent stability through rubberised feet
- Overheating protection

- 230 V, 50 Hz, 900 W
- WxHxD approx. 225 x 115 x 225 mm

Sandwich toaster
ST 5016 CB

- Non-stick coating
- Heat insulated handle
- Automatic temperature controller
- 2 control lamps for power and heating (baking lights)
- Locking system
- Safety shutdown
- Overheating protection

- 220-240 V, 50 Hz, 750 W
- WxHxD approx. 230 x 80 x 230 mm

● Art. no. 650 210
EAN 4 004 470 616 842 PU 6



● Art. no. 650 201
EAN 4 004 470 616 859 PU 6



● Art. no. 650 160
EAN 4 004 470 501 605 PU 6
● Art. no. 650 163
EAN 4 004 470 501 636 PU 6





Sandwich toaster
ST 1363 CB

NEW! **Sandwich toaster**
ST 1372 CB

NEW! **Sandwich toaster**
ST 1472

- Stainless steel insert
- Non-stick coating
- Heat insulated handle
- Automatic temperature control
- 2 control lamps for power and heating (baking lights)
- High stability through rubberized feet
- Locking system
- Overheating protection
- Cord storage

- 220–240 V, 50/60 Hz, 700 W
- WxHxD approx. 235 x 100 x 225 mm

- Stainless steel insert
- Triangular sandwich plates
- Non-stick coating
- Heat insulated handle
- Automatic temperature control
- 2 control lamps for power and heating (baking lights)
- High stability through rubberized feet
- Locking system
- Overheating protection

- 220–240 V, 50/60 Hz, 750 W
- WxHxD approx. 235 x 95 x 235 mm

- 4-slice sandwich toaster
- Stainless steel insert
- Triangular sandwich plates
- Non-stick coating
- Heat insulated handle
- Automatic temperature control
- 2 control lamps for power and heating (baking lights)
- High stability through rubberized feet
- Locking system
- Overheating protection and overtemperature protection

- 220–240 V, 50/60 Hz, 1200 W
- WxHxD approx. 270 x 105 x 325 mm



Stainless steel insert



Stainless steel insert



Stainless steel insert

● **Art. no. 613 631**
EAN 4 004 470 616 774

PU 6



● **Art. no. 613 721**
EAN 4 004 470 637 359

PU 6



● **Art. no. 614 720**
EAN 4 004 470 637 366

PU 4





3in1



Stainless steel housing



34

Multi grill
ST/WA 1364 CB

- Sandwich toaster, waffle maker and contact grill
- Versatile use by three different removable plates (sandwich/waffle/grill plates), e.g. for Belgian waffles and tasty sandwich variations, as well as for fast two-sided contact grilling
- Stainless steel insert
- Baking plates non-stick coated and changeable
- Heat insulated handle
- 2 control lamps for power and heating (baking lights)
- High stability through rubberized feet
- Locking system
- Overheating protection
- 230 V, 50/60 Hz, 650 W
- W x H x D approx. 230 x 100 x 225 mm

Multi grill
MG 2251 CB

- Multi grill for double-sided, fat-free grilling
- Versatile, can be used for e.g. panini, steaks, fish or vegetables
- Stainless steel housing
- Short cooking times
- Non-stick grill plates with extra deep grooves for strong grill pattern
- Heat insulated handle
- Control lamp
- Grilling surfaces: 23 x 14,5 cm
- Cord storage
- 220-240 V, 50/60 Hz, 700W
- W x H x D approx. 270 x 95 x 230 mm



Stainless steel insert



Sandwich plates, waffle plates, grill plates



Stainless steel housing

● **Art. no. 613 641**
EAN 4 004 470 616 781 PU 4



● **Art. no. 622 511**
EAN 4 004 470 225 112 PU 6





Ice cube maker
EWB 1027 CB

Soft ice cream maker
ICM 387 CB

Yogurt maker
JM 1025 CB

- Compact ice cube maker without complicated installation for producing ice cubes quickly and simply at the press of a button
- Ideal for home use, in offices, when camping or for small bars
- No water pipe required, simply fill water into the tank (2.2-l-water tank)
- Approx. 10–15 kg of ice cubes in 24 hours (approx. 90 g in 10 min – corresponding to 9 ice cubes)
- LED display and acoustic signal when the ice cube container is full or the water tank is empty
- Energy-saving mode – automatic switch-off at the end of the program
- On/off switch
- 3 control lamps (ice full, empty water, operation)
- Visual check through viewing window in the lid
- Low-noise
- 220–240 V, 50/60 Hz, 95 W (Cooling), 165 W (spending ice cubes)
- W x H x D approx. 245 x 330 x 370 mm

- Soft ice cream maker with discharge valve for preparation of soft ice cream, ice cream, frozen yogurt, and sorbet
- Lid with replenishing aperture
- With portioner – ice dispensed directly from the machine
- On/off switch
- Incl. recipe suggestions
- Capacity max. 1 litre
- Double-walled ice cream maker with cold storage, removable for easy cleaning (H: 14 cm; Ø 17 cm)
- Stirring element with powerful, quiet motor
- Excellent stability through rubberised feet
- 220–240 V, 50 Hz, 18 W
- W x H x D approx. 220 x 440 x 225 mm

- Easy preparation of up to 1.1 litres of yoghurt
- 7 practical portion jars with screw cap (capacity: 160 ml)
- On/off switch (illuminated)
- Transparent lid
- Additional jars in a set of 6 also available as an optional EG JM 3344, Product number: 251 125
- 230 V, 50 Hz, 14 W
- W x H x D approx. 240 x 150 x 265 mm

Suitable replacement jar:
EG JM 3344
Art. no.: 251 125
EAN: 4 006 160 511 253



LED displays For approx. 10–15 kg ice cubes



Soft ice cream maker with discharge valve



Art. no. 610 271
EAN 4 004 470 102 710 PU 1

Art. no. 603 870
EAN 4 004 470 038 705 PU 2

Art. no. 610 250
EAN 4 004 470 102 505 PU 6





Egg boiler
EK 5022 CB

- Preparation of up to 6 eggs
- Heating dish non-stick coated
- On/off switch (illuminated)
- Acoustic signal (buzzer)
- Removable egg holder
- Incl. measuring beaker with egg pricker
- 230 V, 50 Hz, 400 W
- WxHxD approx. 220 x 130 x 135 mm



Electric pepper/salt mill
PSM 437 N CB

- High-quality precision ceramic grinder
- Stainless steel housing
- Adjustable ceramic grinder (from coarse to fine)
- Consistent grinding quality
- Simple refilling
- Single-handed operating
- Incl. light for optimum dosing of the condiment
- Battery-operated
- Battery operation:
4x1,5 V AA/Mignon/LR/AM3 (batteries not included)
- WxHxD approx. 45 x 220 x 45 mm



Food slicer
AS 432 CB

- Special stainless steel blade (rustproof)
- Powerful motor
- 3-step switch
- Safety power switch
- Infinitely adjustable cutting thickness
- Cutting thickness indication
- Food holder with finger guard
- Removable slide
- Foldable housing
- 220–240 V, 50/60 Hz, 180 W max.
- WxHxD approx. 280 x 230 x 310 mm



● Art. no. 650 220
EAN 4 004 470 616 866 PU 6
● Art. no. 650 223
EAN 4 004 470 502 237 PU 6
● Art. no. 650 228
EAN 4 004 470 502 282 PU 6



● Art. no. 604 372
EAN 4 004 470 043 723 PU 6



● Art. no. 604 320
EAN 4 004 470 043 204 PU 6





Incl. transparent mixing vessel

Metal food slicer
MA 451 CB

Hand blender
SM 354 CB

Hand blender
SM 384 CB

- Big stainless steel blade (Ø 190 mm), rustproof
- Universal serrated blade
- Motor housing: aluminium die cast
- On/off switch
- Metal guiding rail
- Metallic guiding board
- Food grip with finger protection
- Continuously adjustable cutting size (0–15 mm)
- Tilted supporting table with stainless steel insert, tiltable for easy cleaning
- Non-slip stand by suction feet

- 220–240 V, 50/60 Hz, 150 W
- WxHxD approx. 365 x 235 x 265 mm

- Stainless steel cutting blade
- On/off switch (countersunk)
- Incl. transparent mixing vessel (500 ml)
- Hanging loop
- Wall holder plus attachment materials

- 220–240 V, 50 Hz, 180 W
- WxHxD approx. 80 x 330 x 80 mm

- Stainless steel cutting blade (rustproof)
- On/off switch (countersunk)
- Powerful 180 watt motor
- Incl. transparent mixing vessel (500 ml)
- Hanging loop

- 220–240 V, 50 Hz, 180 W
- WxHxD approx. 80 x 330 x 80 mm



Incl. transparent mixing vessel (500 ml)



Can also be combined as a suitable kitchen set

● **Art. no. 604 510**
EAN 4 004 470 045 109 PU 2

● **Art. no. 603 540**
EAN 4 004 470 035 407 PU 12

● **Art. no. 603 842**
EAN 4 004 470 038 422 PU 8
● **Art. no. 603 846**
EAN 4 004 470 038 460 PU 8
● **Art. no. 603 848**
EAN 4 004 470 038 484 PU 8





3in1

38

Hand blender
SM 357 CB

- Stainless steel cutter
- Soft touch housing
- Powerful 300 watt motor
- 2-level push button switch
- Removable stainless steel hand blender
- Ergonomic design handle
- Incl. mixing vessel with scale (0.6 litre)

- 230-240 V, 50 Hz, 300 W
- WxHxD approx. 65 x 370 x 65 mm

Hand blender set
SMS 349 CB

- Hand blender set – stainless steel hand blender, multiple chopper and whisk in one
- Working container with scale (0,5 litre)
- Powerful 200 watt motor
- 2 speeds
- Removable metal whisk
- Ergonomically shaped rubberised handle for easier handling
- Holder for metal whisk and stainless steel hand blender
- Incl. mixing vessel with scale (0.7 litre)
- Hanging loop

- 220–240 V, 50/60 Hz, 200 W
- WxHxD approx. 160 x 370 x 150 mm



Incl. mixing vessel with scale (0.6 litre)



● **Art. no. 603 571**
EAN 4 004 470 035 711 PU 6



● **Art. no. 603 491**
EAN 4 004 470 034 912 PU 6





4in1

Hand blender set SMS 374 CB

- Hand blender set (hand blender, whisk, ice-crusher, food processor)
 - 7 functional options
 - Stainless steel housing
 - Powerful 750 watt motor
 - Incl. ice-crush function
 - Variable speed regulation, illuminated in blue
 - Incl. turbo setting for heavy applications
 - Soft-touch press-button
 - Ergonomically shaped, rubberized handle for easier handling
 - Stainless steel mixing rod and metal whisk, detachable
 - Work container with scale and refill opening (1.25 litre capacity)
 - High-grade, interchangeable attachments from stainless steel for chopping and grating
 - Attachments: grating, cutting and potato-grating insert, chopper, transparent mixing container with scale (0.6 litre)
 - Quick and easy assembly of the accessories
- 220–240 V, 50/60 Hz, 750 W
 - W x H x D approx. 70 x 390 x 70 mm



Variable speed regulation



Incl. whisk



Multi express ME 467 CB

- Electrical shredding unit "Multi Express"
 - Large and changeable high-quality drum attachments made of stainless steel, for quick and easy cutting or grating
 - Easy handling
 - 5 functions:
 - cutting (fine/coarse) of, for example, onions, cucumbers
 - grating (fine/coarse) of, for example, carrots, radishes
 - shredding for example of parmesan, nuts, potatoes
 - Powerful 150 W motor
 - Large filler opening (ca. Ø 60 mm)
 - Wide discharge opening (ca. Ø 80 mm)
 - Accessories: 2 cutting attachments (fine/coarse), 2 grating attachments (fine/coarse), 1 shredding attachment
- 220–240 V, 50/60 Hz, 150 W
 - W x H x D approx. 150 x 275 x 230 mm

Fine cutting
e.g. onionsCoarse cutting
e.g. cucumbersFine grating
e.g. potatoesCoarse grating
e.g. carrotsShredding
e.g. parmesan



2in1

**Multi chopper
& ice-crusher**



2in1

**Multi chopper
& ice-crusher**



2in1

**Multi chopper
& ice-crusher**

40

Multi chopper
MZ 449 CB

- Mixing bowl (1 litres capacity)
 - Removable chopping blade (rustproof)
 - Incl. ice-crusher function
 - Safe base
 - Easy to clean
- 220–240 V, 50/60 Hz, 250 W
 - WxHxD approx. 175 x 220 x 175 mm

Multi chopper
MZ 449 CB

- Mixing bowl (1 litre capacity)
 - Removable chopping blade (rustproof)
 - Incl. ice-crusher function
 - Safe base
 - Easy to clean
- 220–240 V, 50/60 Hz, 250 W
 - WxHxD approx. 175 x 220 x 175 mm

Multi chopper
MZ 450 CB

- Mixing bowl made of glass (1.2 litres capacity)
 - Removable chopping blade (stainless steel, rustproof)
 - 2-level pulse switching
 - Incl. ice-crusher function
 - Mixing bowl suitable for microwave oven
 - Safe base
 - Easy to clean
- 220–240 V, 50/60 Hz, 300 W
 - WxHxD approx. 175 x 265 x 175 mm



Can also be combined as a suitable kitchen set

● **Art. no. 604 490**
EAN 4 004 470 044 904 PU 6



● **Art. no. 604 492**
EAN 4 004 470 044 928 PU 6
● **Art. no. 604 496**
EAN 4 004 470 044 966 PU 6
● **Art. no. 604 498**
EAN 4 004 470 044 980 PU 6



● **Art. no. 604 500**
EAN 4 004 470 045 000 PU 6





2in1

Multi chopper
& ice-crusher



2in1

Multi chopper
& ice-crusher



Multi chopper
MZ 464 CB

- Large mixing bowl made of glass (1.5 litres capacity)
- 2 removable chopping blades (stainless steel, rustproof)
- 2-level pulse switching
- Incl. ice-crusher function
- Mixing bowl suitable for microwave oven
- Stainless steel insert
- Safe base
- Easy to clean
- 220–240 V, 50/60 Hz, 300 W
- WxHxD approx. 175 x 280 x 175 mm

Multi chopper
MZ 1568 CB

- Mixing bowl made of glass (1.2 litres capacity)
- 2 removable chopping blades (stainless steel, rustproof)
- Incl. ice-crusher function
- Mixing bowl suitable for microwave oven
- Stainless steel insert
- Safe base
- Easy to clean
- 220–240 V, 50 Hz, 300 W
- WxHxD approx. 175 x 280 x 175 mm

Hand mixer
HM 350 CB

- Powerful 250 watt motor
- 5 speed level
- Eject button
- Stainless steel dough hooks and beaters
- All accessories are dishwasher-safe
- 230 V, 50 Hz, 250 W
- WxHxD approx. 180 x 280 x 90 mm



Stainless steel insert



Can also be combined as a suitable kitchen set

● Art. no. 604 641
EAN 4 004 470 046 410

PU 6



● Art. no. 615 681
EAN 4 004 470 156 812
● Art. no. 615 684
EAN 4 004 470 156 843

PU 6

PU 6



● Art. no. 603 500
EAN 4 004 470 035 001

PU 6





Hand mixer
HM 350 CB

- Powerful 250 watt motor
 - 5 speed level
 - Eject button
 - Stainless steel dough hooks and beaters
 - All accessories are dishwasher-safe
- 230 V, 50 Hz, 250 W
■ WxHxD approx. 180 x 280 x 90 mm

Hand mixer
CB 334

- Powerful 200 watt motor
 - 5 speeds
 - Turbo switch
 - Eject button
 - Kneading hooks and beaters (chromium-plated)
 - All accessories are dishwasher-safe
- 230 V, 50/60 Hz, 200 W
■ WxHxD approx. 200 x 260 x 80 mm



Can also be combined as a suitable kitchen set

- **Art. no. 603 502**
EAN 4 004 470 035 025 PU 6
- **Art. no. 603 506**
EAN 4 004 470 035 063 PU 6
- **Art. no. 603 508**
EAN 4 004 470 035 087 PU 6

- **Art. no. 603 340**
EAN 4 004 470 033 403 PU 12





2in1

Hand mixer set
HM 381 CB

- Powerful 300 watt motor
- 5 speeds
- Turbo setting
- Eject button
- Stainless steel dough hooks and beaters (21 cm) (dishwasher-safe)
- 220–240 V, 50/60 Hz, 300 W
- WxHxD approx. 90 x 145 x 200 mm



2in1

Hand mixer set
HM 377 CB

- Hand mixer in an attractive stainless steel design
- Powerful 300 watt motor
- 5 speeds
- Turbo setting
- Eject button
- Soft touch handle insert – for safe handling
- Accessory: 2 stainless steel beaters, 2 stainless steel dough hooks, stainless steel blender
- Incl. convenient storage tray (also suitable for wall mounting, incl. installation material)
- All accessories dishwasher-safe
- 220–240 V, 50 Hz, 300 W
- WxHxD approx. 210 x 290 x 160 mm



2in1

Hand mixer set
CB 336

- Powerful 250 watt motor
- 5 speeds
- Turbo setting
- High-speed blender attachment
- With fine steel knife, Stainless steel beaters and dough hooks
- Large mixing bowl with automatic drive
- All accessories dishwasher-safe
- 230 V, 50/60 Hz, 250 W
- WxHxD approx. 300 x 350 x 200 mm



Incl. quick blender



Incl. 2 stainless steel beaters and 2 stainless steel dough hooks



Incl. stainless steel blender



Incl. quick blender

Art. no. 603 810
EAN 4 004 470 038 101

PU 6

Art. no. 603 771
EAN 4 004 470 037 715

PU 4

Art. no. 603 360
EAN 4 004 470 033 601

PU 2





1200 Watt

Food processor
KM 392 CB

- Variable electronic speed control + pulse function
 - Electronic timer function
 - 4.2 litre fine steel dish for max. 1,7 kg mixture preparation
 - Aluminium die-cast stirring hook – also enables the uniform mixing of sizeable quantities of dough
 - Aluminium die-cast dough hook – for heavy doughs, e.g. yeast or bread dough
 - Stainless steel whisk for light sponge cake and fluffy egg whites
 - Constant power through load-dependent, electronic speed control
 - 35° swivelling multifunction arm
 - Unlocking mechanism for multifunction arm
 - Safety circuit
 - Transparent splash protection lid (detachable)
 - Particularly easy to operate and clean
 - Non-slip stand by suction feet
 - Base station with cord storage
 - Quick-action chuck for holding the tools
- 220–240 V, 50 Hz, 600 W
■ W x H x D approx. 365 x 309 x 220 mm

Kneading and stirring machine
KM 370 CB

- High-performance kneading machine with extra-powerful 1200 watt
 - 7 speed settings plus pulse (0-1-2-3-4-5-6)
 - 5 litre fine steel dish for max. 2 kg mixture preparation
 - Aluminium die-cast stirring hook – also enables the uniform mixing of sizeable quantities of dough
 - Aluminium die-cast dough hook – for heavy doughs, e.g. yeast or bread dough
 - Stainless steel whisk for light sponge cake and fluffy egg whites
 - Special robust gear mechanism
 - Constant power through load-dependent, electronic speed control
 - 60° swivelling multifunction arm
 - Unlocking mechanism for multifunction arm
 - Safety circuit
 - Particularly easy to operate and clean
 - Non-slip stand by suction feet
 - Quick-action chuck for holding the tools
- 220–240 V, 50/60 Hz, 1200 W
■ W x H x D approx. 370 x 370 x 230 mm



● Art. no. 603 921
EAN 4 004 470 039 214 PU 2



● Art. no. 603 700
EAN 4 004 470 037 005 PU 1





ELECTRONIC

1200 Watt



NEW! Kneading and stirring machine
KM 305 CB

- Powerful food processor/kneading machine with extra-powerful 1200 watt max.
 - 5-level switch (0-1-2-3-4)
 - 5 LED control lamps (blue illuminated)
 - 5.6 litre fine steel dish for max. 2.5 kg mixture preparation
 - Stainless steel bowl (rustproof)
 - Aluminium die-cast stirring hook – also enables the uniform mixing of sizeable quantities of dough
 - Aluminium die-cast dough hook – for heavy doughs, e.g. yeast or bread dough
 - Whisk made of stainless steel
 - Special robust gear mechanism
 - Electronic speed control
 - 35° swivelling multifunction arm
 - Unlocking mechanism for multifunction arm
 - Safety circuit (can only be operated with the lid in position or with cover)
 - Transparent splash protection lid
 - Particularly easy to operate and clean
 - Non-slip stand by suction feet
- 220–240 V, 50 Hz, 1200 W max.
 - W x H x D approx. 390 x 350 x 280 mm



Electronic circuit



35° swivelling multifunction arm

● **Art. no. 603 059**
EAN 4 004 470 030 594

PU 1

● **Art. no. 603 054**
EAN 4 004 470 030 549

PU 1

● **Art. no. 603 056**
EAN 4 004 470 030 563

PU 1





2in1



ELECTRONIC



46

NEW! Kneading and stirring machine set
KM 315 CB

Kneading and stirring machine set

- Powerful food processor/kneading machine with extra powerful 1200 watts max.
 - 5-level switch (0-1-2-3-4)
 - 5 LED control lamps (blue illuminated)
 - 5.6 litre fine steel dish for max. 2.5 kg mixture preparation
 - Stainless steel bowl (rustproof)
 - Aluminium die-cast stirring hook – also enables the uniform mixing of sizeable quantities of dough
 - Aluminium die-cast dough hook – for heavy doughs, e.g. yeast or bread dough
 - Whisk made of stainless steel
 - Special robust gear mechanism
 - Electronic speed control
 - 35° swivelling multifunction arm
 - Unlocking mechanism for multifunction arm
 - Safety circuit (can only be operated with the lid in position or with cover)
 - Transparent splash protection lid
 - Particularly easy to operate and clean
 - Non-slip stand by suction feet
- 220–240 V, 50 Hz, 1200 W max.
■ W x H x D approx. 390 x 350 x 280 mm



Kitchen scale

- Extra-flat digital kitchen scale
- Weighing surface made of high-quality glass
- Clearly legible LCD display
- Weights up to 5 kg (1 g scaling)
- Adjustable measuring units: g, lb-oz, ml, fl-oz
- Automatic switch-off
- On/off switch
- Tare function (additive weighed function)
- High stability through rubberized feet
- Low battery indicator

- Battery-operated:
1x CR 2032
(battery included)
- W x H x D approx.
150 x 17 x 220 mm



Electronic circuit



35° swivelling multifunction arm

Art. no. 603 151
EAN 4 004 470 031 515 PU 1





1200 Watt



Kneading and stirring machine KM 383 CB

47

- High-performance kneading machine with extra-powerful 1200 watt
 - Variable electronic speed control + pulse function
 - 6.5 litre fine steel dish for max. 3–4 kg mixture preparation
 - Aluminium die-cast stirring hook (non-stick coated) – also enables the uniform mixing of sizeable quantities of dough
 - Aluminium die-cast dough hook (non-stick coated) – for heavy doughs, e.g. yeast or bread dough
 - Stainless steel whisk for light sponge cake and fluffy egg whites
 - Special robust gear mechanism
 - Constant power through load-dependent, electronic speed control
 - 35° swivelling multifunction arm
 - Unlocking mechanism for multifunction arm
 - Safety circuit
 - Particularly easy to operate and clean
 - Non-slip stand by suction feet
 - Quick-action chuck for holding the tools
- 220–240 V, 50 Hz, 1200 W
 - WxHxD approx. 460 x 331 x 233 mm

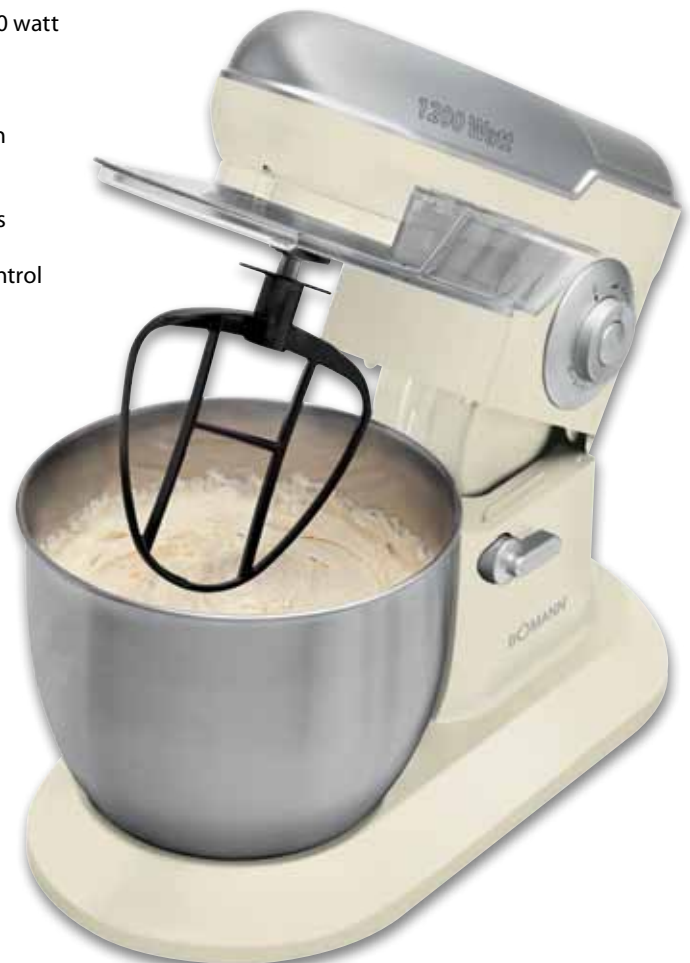

● Art. no. 603 831 ● Art. no. 603 830 ● Art. no. 603 836 ● Art. no. 603 834
 EAN 4 004 470 038 316 PU 1 EAN 4 004 470 038 309 PU 1 EAN 4 004 470 038 361 PU 1 EAN 4 004 470 038 347 PU 1





1200 Watt

35° swivelling
multifunction arm



48

NEW! Food processor
KM 398 CB

- High-performance kneading machine with extra-powerful 1200 watt
 - 8 speed level (0/1/2/3/4/5/6 + pulse function)
 - 6.2 litre fine steel dish for max. 3–4 kg mixture preparation
 - Aluminium die-cast stirring hook (non-stick coated) – also enables the uniform mixing of sizeable quantities of dough
 - Aluminium die-cast dough hook (non-stick coated) – for heavy doughs, e.g. yeast or bread dough
 - Stainless steel whisk for light sponge cake and fluffy egg whites
 - Special robust gear mechanism
 - Constant power through load-dependent, electronic speed control
 - 35° swivelling multifunction arm
 - Unlocking mechanism for multifunction arm
 - Safety circuit
 - Particularly easy to operate and clean
 - Non-slip stand by suction feet
 - Quick-action chuck for holding the tools
- 220–240 V, 50 Hz, 1200 W
 - WxHxD approx. 402 x 326 x 212 mm



● Art. no. 603 980
EAN 4 004 470 039 801 PU 1



Incl. mixer attachment



2in1

1200 Watt

Food processor
KM 385 CB

- High-performance kneading machine with extra-powerful 1200 W
- Variable electronic speed control + pulse function
- 6.5 litre fine steel dish for max. 3–4 kg mixture preparation
- Glass mixing container with scale and filler opening 1.5 litre capacity
- Aluminium die-cast stirring hook (non-stick coated) – also enables the uniform mixing of sizeable quantities of dough
- Aluminium die-cast dough hook (non-stick coated) – for heavy doughs, e.g. yeast or bread dough
- Stainless steel whisk for light sponge cake and fluffy egg whites
- Special robust gear mechanism
- Constant power through load-dependent, electronic speed control
- 35° swivelling multifunction arm
- Unlocking mechanism for multifunction arm
- Safety circuit
- Particularly easy to operate and clean
- Non-slip stand by suction feet
- Quick-action chuck for holding the tools
- 220–240 V, 50 Hz, 1200 W
- WxHxD approx. 460 x 331 x 233 mm

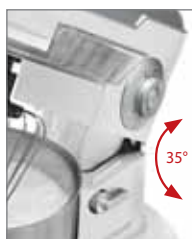

2in1



ELECTRONIC

Kneading and stirring machine
incl. meat mincer KM 369 CB

- High-performance kneading machine with extra-powerful 1000 W
- 6-level switch (1-2-3-4-5-6)
- 7 LED control lamps, illuminated in blue
- 5 litre fine steel dish for max. 2 kg mixture preparation
- Aluminium die-cast stirring hook – also enables the uniform mixing of sizeable quantities of dough
- Aluminium die-cast dough hook – for heavy doughs, e.g. yeast or bread dough
- Stainless steel whisk for light sponge cake and fluffy egg whites
- Special robust gear mechanism
- Electronic speed control
- 35° swivelling multifunction arm
- Unlocking mechanism for multifunction arm
- Safety circuit
- Transparent splash protection lid, detachable
- Particularly easy to operate and clean
- Non-slip stand by suction feet
- Protective cover for drive axle

Mincer

- Stainless steel blades, metal refill tray, metal tube, metal cutter, 3 steel mincing disks (5/3/2 mm)
- Biscuit attachment, sausage filler accessory
- Kebbe attachment - oriental cuisine
- 220–240 V, 50 Hz, 1000 W
- WxHxD approx. 534 x 455 x 234 mm



Art. no. 603 850
EAN 4 004 470 038 507

PU 1



Art. no. 603 691
EAN 4 004 470 036 916

PU 1





4in1



ELECTRONIC

Multi-functional food processor KM 372 CB

- Solid multi-food-processor with aluminium die-cast body
- Powerful long-life professional motor, 1400 watt max.
- Consistent performance due to load-dependent electronic rotation speed control
- 4 electronic speed programs
- Continuous speed control
- Smooth start – slow mixing at the start avoids dough spattering
- Extra huge 6 litre stainless steel bowl with handle – for preparation of 3 kg mixture maximum
- Confectioner set with 3 professional tools enables kneading and mixing of difficult dough and mixtures as well
- Special dough hooks for heavy dough such as e.g. yeast, bread and noodle dough
- Metal beater for lighter dough such as shortcrust, crumble, sponge cake dough and many more
- Stainless steel wire whisk with splash guard for whisking egg whites, cream, meringue and many more kinds of foods
- Splash guard cover with refill opening
- Special solid gear machine
- Swivelling multifunction arm with unlocking mechanism
- Safety switching – stops at the arm being raised
- Easy to operate and to clean
- Non-slip stand due to suction cup feet
- 220–240 V, 50/60 Hz, 1400 W max.

Mixing attachment

- Glass mixing jug with scale (1.5 litre)
- For pureeing, whisking, shredding, shaking and mixing
- Perfect for preparing fruit and fitness drinks, milk shakes, cocktails, soups, salsa sauces and baby food. Also possible: smoothies, vegetable purees, dips, spice pastes and a lot more
- 6-leaf stainless steel knife for mixing without problems, easily removable for cleaning
- Safety switching – operation possible only with the fitted container
- Revolutions/minute: 15000 max.

Meat mincing machine

- Metal neck, metal worm gear, 3 perforated steel discs, stainless steel knife, sausage filling attachment, attachment for extruded shortbread cookies (4 shapes), Kibbeh attachment for oriental stuffed pastries, metal refilling tray

Pasta maker

- Create your own pasta with 4 different attachments, e.g. spaghetti, macaroni, tagliatelle

Art. no. 603 721
EAN 4 004 470 037 210

PU 1



4in1



Multi food processor KM 367 CB

51

- Extra-powerful motor with max. 1000 watt
- 6 speeds plus pulsed operation
- 5 litre fine steel dish for max. 2 kg mixture preparation
- Mixing vessel with scale and filling aperture, 1.5 litres capacity
- Special kneading hook (spray protection) for yeast and bread dough
- Metal stirring hook with spray protection
- Metal whisk with spray protection
- Sturdy special gears
- Swivelling multi-function arm with unlocking mechanism
- Splash guard cover with filling aperture
- Particularly easy to operate and clean
- Safety circuit
- Non-slip stand by suction feet

Mincer

- Metal tube, metal cutter, 3 steel mincing disks, stainless steel cutter, sausage filler accessory, biscuit attachment, metal refill tray

Pasta maker

- Make pasta yourself with 5 different attachments, e.g. spaghetti, macaroni, tagliatelle
- Incl. box for storing the pasta attachments
- 220–240 V, 50/60 Hz, 1000 W max., 600 W nom.
- W x H x D approx. 250 x 575 x 400 mm



Pasta maker

Mixing
accessory

Spaghetti attachment



Spaghetti attachment, narrow



Kneading and stirring



Mincer



Tagliatelle attachment



Lasagne sheets attachment



Penne-/Macaroni attachment

4in1



1200 Watt

Food processor
KM 345 CB

Mincer
FW 447 CB

- Powerful kitchen machine with max. 550 watt motor
- 5 speed settings plus pulse (0/1/2/3/4)
- Mixing vessel with scale (1.5 litre capacity)
- High-quality, changeable utensils and work blades
- Safety switch
- Accessories: cutting disc, guillotine knife, kneading knife, grating disc, plastic spatula
- 220–240 V, 50 Hz, 550 W max.
- W x H x D approx. 380 x 380 x 250 mm

- Chrome-plated front plate
- Metal neck
- Metal feed tray
- Metal feed screw
- 3 stainless steel discs (7/5/3 mm)
- Stainless steel knife
- Reverse function
- Cookie maker attachment
- Sausage filler accessory
- Kebbe attachment – oriental cuisine
- On/off switch
- Non-slip stand by suction feet
- 220–240 V, 50/60 Hz, 1200 W max.
- W x H x D approx. 330 x 355 x 170 mm



Integrated storage compartment for accessories

Incl. 3 stainless steel discs, cookie maker attachment, kebbe attachment, sausage filler accessory

● Art. no. 603 451
EAN 4 004 470 034 516 PU 2

● Art. no. 604 471
EAN 4 004 470 044 713 PU 4





2in1

Universal mixer
UM 378 CB

- Universal mixer for pureeing, beating, chopping, shaking and mixing
- Ideal for preparing fruit and fitness drinks, milk shakes, cocktails, soups, salsa sauces, baby food
- For kitchen and bar
- Ice-crusher function
- Powerful max. 500 watt motor
- 5 level switch (0-1-2-3-4 + pulse/turbo function)
- Removable mixing bowl (1.5 litre capacity)
- Lid with replenishing aperture
- Cover for the filling aperture can also be used as a measuring beaker (2 cl)
- Stainless steel blade (rustproof)
- Safety circuit – operation only possible with vessel in place
- Excellent stability through rubberized feet

- 220–240 V, 50/60 Hz, 500 W max.
- W x H x D approx. 160 x 400 x 160 mm

Universal mixer
UM 1569 CB

- Universal mixer for pureeing, beating, chopping, shaking and mixing
- Ideal for preparing fruit and fitness drinks, milk shakes, cocktails, soups, salsa sauces, baby food
- For kitchen and bar
- Stainless steel front
- Incl. ice-crusher function
- Powerful 600 watt motor
- 4 level switch (0-1-2 + pulse/turbo function)
- Removable mixing bowl made of solid glass with scale (1.5 litre capacity)
- Lid with replenishing aperture
- Cover for the filling aperture can also be used as a measuring beaker (5 cl)
- 4-fold stainless steel blade (rustproof)
- Safety circuit – operation only possible with vessel in place
- Knife block removable for cleaning
- Excellent stability through rubberised feet

- 220–240 V, 50/60 Hz, 600 W
- W x H x D approx. 185 x 410 x 200 mm



Can also be combined as a suitable kitchen set

Art. no. 603 780
EAN 4 004 470 037 807 PU 4



Art. no. 615 691
EAN 4 004 470 156 911 PU 4
Art. no. 615 694
EAN 4 004 470 156 942 PU 4





2in1  **Stainless steel**



Mixing cup also suitable as drinking cup

54

Universal mixer UM 1354 CB

- Stainless steel universal mixer for pureeing, beating, chopping up, shaking and mixing
 - Ideal for preparing fruit and fitness drinks, milk shakes, cocktails, soups, salsa sauces, baby food
 - For kitchen and bar
 - Stainless steel housing
 - Ice-crusher function
 - Powerful max. 650 watt motor
 - 4 level switch (0-1-2-impulse)
 - Rotary switch (blue illuminated)
 - Removable mixing vessel made of solid glass with 1.5 litre capacity (with scale)
 - Lid with replenishing aperture
 - Cover for the filling aperture can also be used as a measuring beaker (2 cl)
 - 6-fold stainless steel blade (rustproof)
 - Safety circuit – operation only possible with vessel in place
 - All accessories are dishwasher-resistant
 - Knife block removable for cleaning
 - Excellent stability through rubberised feet
 - Cable storage compartment in the base section
- 220–240 V, 50/60 Hz, 650 W max.
■ WxHxD approx. 200 x 410 x 185 mm

Smoothie maker SM 386 CB

- Universal mixer for pureeing, beating, chopping up, shaking and mixing, consisting of base, mixing cup and lid with drinking aperture
 - “Mix & Go” – Mix your favorite shake in a few minutes. With the practical drinking aperture, you can take your freshly prepared shake with you to work, school or sports
 - Ideal for preparing fruit and fitness drinks, milk shakes, cocktails, soups, salsa sauces, baby food
 - Incl. recipe suggestions
 - Incl. lid with drinking aperture
 - Ideal for kitchen, bar and on the road
 - Powerful motor, 250 W
 - 1 speed (pulse)
 - Detachable mixing container (600 ml)
 - Stainless steel blade (rustproof)
 - Safety circuit – operation only possible with vessel in place
 - All accessories dishwasher safe
 - Excellent stability through rubberized suction pads
- 220–240 V, 50 Hz, 250 W
■ WxHxD approx. 130 x 370 x 125 mm

Replacement bottle for Smoothie maker

 **Art. no. 264 559**
EAN 4 006 160 645 590 **VE 6**



 **Art. no. 613 541**
EAN 4 004 470 135 411 **PU 4**



 **Art. no. 603 862**
EAN 4 004 470 038 620 **PU 6**
 **Art. no. 603 866**
EAN 4 004 470 038 668 **PU 6**
 **Art. no. 603 868**
EAN 4 004 470 038 682 **PU 6**





Citrus fruit squeezer
ZP 1092 CB

- Removable bowl with aroma protective cover (1.2 litre)
- 2 press cones
- Automatic start/stop function by pressing juicer cone
- Automatic clockwise/anticlockwise operation for optimal juice extraction
- Practical cable tidy

- 230 V, 50 Hz, 40 W
- WxHxD approx. 180 x 230 x 180 mm



Automatic juicer
AE 1028 CB

- Powerful 400 watt max.
- Fresh fruit and vegetable juices quickly prepared. Rich in vital substances for well-being, fitness and health
- 30% more juice and vitamins
- Removable pulp container
- Removable juice container
- On/off switch
- Lock with safety switch
- Stainless steel micro-strainer for finest juices
- Can be completely taken apart for rapid and unproblematic cleaning
- Safe stand

- 220–240 V, 50 Hz, 350–400 W max.
- WxHxD approx. 235 x 330 x 210 mm



Professional automatic juicer AE 1917 CB

- Professional automatic juicer in high-quality stainless steel housing
- Fresh fruit and vegetable juices quickly prepared. Rich in vital substances for well-being, fitness and health
- 30 % more juice and vitamins
- Extra large filler spout (75 mm Ø)
- Extracts the juice from apples, carrots and other fruits within seconds without having to chop them
- Powerful 1000 watt motor max.
- 2 speed settings (0-1-2) for different fruit hardness
- High volume pulp container (approx. 2.0 litre capacity)
- Open stainless steel juice spout
- Flexible anti-drip juice spout – no splashes and no wiping
- Lock with safety switch
- Stainless steel sieve for finest juices
- Can be completely disassembled – quick and easy cleaning
- High stability

- 230 V, 50 Hz, 1000 W max.
- WxHxD approx. 300 x 400 x 220 mm



Stainless steel



NEW! Glass kitchen scale
KW 1515 CB

Kitchen scale
KW 1421 CB

Food dryer
DR 448 CB

- Extra-flat digital kitchen scale
- Weighing surface made of high-quality glass
- Clearly legible LCD display
- Weights up to 5 kg (1 g scaling)
- Adjustable measuring units: g, lb-oz, ml, fl-oz
- Automatic switch-off
- On/off switch
- Tare function (additive weighed function)
- High stability through rubberized feet
- Low battery indication
- Battery-operated: 1 x CR 2032 (batterie supplied)
- W x H x D approx. 150 x 17 x 220 mm

- Extra-flat digital kitchen scales with permanent clock und temperature information
- Stainless steel weighing surface
- Clearly legible, high-quality multifunction LCD display
- Weights up to 5 kg (1 g scaling)
- Adjustable measuring units: kg, g, lb, oz
- Automatic switch-off for weighing function
- On/off switch
- Tare function (additive weighed function)
- Battery-operated: 3 x AAA (batteries supplied)
- W x H x D approx. 160 x 18 x 230 mm

- Foot dryer dries fruit, vegetables, herbs, meat etc. Rich in essential minerals for well-being, fitness and health
- 2 temperature stages
- Variable use by 5 large, transparent, and stackable levels (easy cleaning)
- Circulation fan, air circulation function
- Overheating protection
- 230 V, 50 Hz, 300 W
- W x H x D approx. 330 x 315 x 327 mm



Can also be combined as a suitable kitchen set



Variable use by 5 large, transparent, and stackable levels (easy cleaning)

- Art. no. 615 151
EAN 4 004 470 637 304 PU 6
- Art. no. 615 155
EAN 4 004 470 151 558 PU 6
- Art. no. 615 156
EAN 4 004 470 151 565 PU 6
- Art. no. 615 157
EAN 4 004 470 151 572 PU 6

- Art. no. 614 211
EAN 4 004 470 142 112 PU 6

- Art. no. 604 480
EAN 4 004 470 616 996 PU 4





2in1

Bag sealer FS 1014 CB

- Ideal for dividing food into portions
- Electronically controlled bag sealer
- Seals and separates in one operation
- Strong extraction pump
- With bag storage view window
- 2 indicator lights
- Cord storage in base
- Incl. a roll of film (3 m)
- 230 V, 50 Hz, 100 W
- WxHxD approx. 330 x 80 x 125 mm

Spare rolls:

Art. no. 282 020
EAN 4 004 470 820 201 PU 10



Fondue deep fat pan FFR 1290 CB

- Cool touch housing
- Capacity: 1 litre oil/frying fat
- Deep frying basket with removable handle
- Continuously variable thermostat
- Control panel with display
- 6 fondue forks marked in colour
- Protective ring against spray/fork holder
- Changeable odour and fumes filter
- Overheating protection
- 230 V, 50 Hz, 900 W
- WxHxD approx. 190 x 240 x 190 mm



Deep fat fryer FR 2223 CB

- Cool touch housing
- Capacity: approx. 2 litre oil/frying fat
- Oil container (non-stick coated)
- Large frying basket, can be raised and lowered with the lid closed
- Pop-up lid with viewing window (removable)
- On/off switch (0-1)
- Continuously adjustable thermostat with control lamp
- 130 °C – 190 °C
- 2 control lamps for power and heating
- Changeable odour and fumes filter
- Collecting container for condensation
- 2 recessed grips for safe transport
- 230 V, 50 Hz, 1800 W
- WxHxD approx. 245 x 260 x 320 mm



Art. no. 610 140
EAN 4 004 470 101 409 PU 6



Art. no. 612 900
EAN 4 004 470 129 007 PU 4



Art. no. 622 230
EAN 4 004 470 222 302 PU 2





Removable
oil container



Stainless steel

Deep fat fryer
FR 2287 CB

Stainless steel deep fat fryer
FR 2264 CB

- Cool touch housing
- Capacity: 3 litre of oil/frying fat
- Removable oil container (non-stick coated)
- Large frying basket; can be raised or lowered with the lid closed
- Pop-up lid with viewing window
- Continuously adjustable thermostat
- 130 °C – 190 °C
- 30 minute timer with shut-off signal
- 2 control lamps for temperature/operation
- Changeable odour and fumes filter
- Cable rewind
- 230 V, 50 Hz, 2000 W
- WxHxD approx. 260 x 260 x 420 mm

- Housing, lid, heating coil made of stainless steel
- Cool zone technology – heating coils immersed directly in the oil for rapid heating and for odorless frying
- Capacity: 3 litre of oil/frying fat
- Continuously adjustable thermostat with control lamp
- Removable fat container (enamelled)
- Stainless steel heating coil (removable)
- Drip tray
- Handles (thermally insulated)
- Cord storage
- Overheating protection
- 230 V, 50 Hz, 2000 W
- W x H x D approx. 215 x 240 x 405 mm

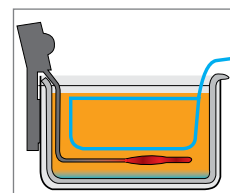

Art. no. 622 870
EAN 4 004 470 228 700 PU 2



Art. no. 622 641
EAN 4 004 470 226 416 PU 2





2in1



Stainless steel



Jam/marmalade program



Wholemeal program



Jam/marmalade program



Wholemeal program

Rice cooker
RK 2282 CB

Bread maker
CB 594

Bread maker
BBA 566 CB

- Rice cooker and steam cooker in one
- Rice cooker for easy preparation and keeping warm all types of rice, pulses, soups, cereals
- Stainless steel housing
- Additional aluminium steamer insert for vitaminretaining steam cooking of e.g. vegetables, potatoes and fish
- Safety glass lid with steam outlet
- Removable, non-stick-coated part
- For max. 1300 g of rice (uncooked weight) yields approximately 2500 g cooked rice
- Automatic keep warm mode
- Automatic switch-off (energy-saving)
- On/off switch
- Cool touch handles
- Removable supply cable
- Safety function: can only be switched on when pot is in position
- 3 control lamps for cooking, keeping warm and mains
- Accessories: measuring beaker (160 ml max.), rice spoon
- 220–240 V, 50 Hz, 700 W
- W x H x D approx. 310 x 310 x 260 mm

- Fully automatic dough and bread preparation (kneading, rising, baking)
- Non-stick coated baking form (removable)
- 3 litre capacity (corresponds to about 1300 g bread)
- 9 baking programs / 31 available settings
- Programs: normal, white bread, wholemeal, sweet bread, dough, cake, sandwich, only baking, quick bake function
- Marmalade program
- Warming function
- Electronic control panel with LCD display and audible signal
- 13 hour timer
- Variably settable dough quantity
- Variable crust browning control (light, medium, dark)
- Cool touch housing
- Lid with viewing window
- 2 kneading pegs
- Accessories: measuring beaker and spoon
- 230 V, 50 Hz, 800 W
- W x H x D approx. 400 x 290 x 260 mm

- Fully automatic dough and bread preparation (kneading, rising, baking)
- Non-stick coated baking form (removable)
- 2 litre capacity (corresponds to about 1000 g bread)
- 12 baking programs / 39 available settings
- Programs: normal, white bread, wholemeal, fast bake, sweet bread, ultra fast bake I, ultra fast bake II, dough, cake, sandwich, bake
- Marmalade program
- Extra bake function
- Warming function
- Electronic control panel with backlight LCD display
- 13 hour timer
- Variably settable dough quantity
- Variable crust browning control (light, medium, dark)
- Cool touch housing
- Lid with viewing window (removable)
- 1 kneading peg
- Accessories: measuring beaker and spoon
- 230 V, 50 Hz, 600 W
- W x H x D approx. 405 x 305 x 265 mm



Incl. aluminium steamer insert

Art. no. 622 821
EAN 4 004 470 228 212 PU 2

Art. no. 605 940
EAN 4 004 470 059 403 PU 2

Art. no. 605 660
EAN 4 004 470 056 600 PU 2





2in1 Hot dog maker & egg boiler

Steam cooker
DG 1218 CB

- Steam cooker for the healthy cooking of food without burning vitamins
- 3 steam cooker containers (1 lid, 1 rise bowl)
- Semi-transparent water tank (1.6 litre)
- Drip bowl for the collection of juices
- 60 minute timer
- Water replenishable during operation
- Water level indicator
- Easy to clean
- Overheating protection
- 230 V, 50 Hz, 750 W max.
- WxHxD approx. 300 x 420 x 210 mm

Steam cooker
DG 2286 CB

- Steam cooker for the healthy cooking of food without burning vitamins
- Water-inflow-control – faster steam generation
- 3 steam cooker containers, 1 lid, 1 rise bowl
- High-grade steel base
- Programmable digital timer
- Incl. LCD display (blue illuminated)
- Incl. power control light
- Drip pan for collecting liquids
- Water level indicator
- Add more water during operation
- Easy to clean
- Overheating protection
- 220–240 V, 50/60 Hz, 700–800 W
- WxHxD approx. 310 x 445 x 240 mm

Hot dog maker
HDM 462 EK N CB

- Hot dog maker and egg boiler in one
- For 1 to 14 small sausages (e. g. “Frankfurter”, “Vienna sausages”)
- Heated stainless steel skewer
- Preparation of up to 6 eggs
- Removable egg holder
- Transparent steam tank (removable)
- Non-stick coated water bowl
- 2 separate switches for spike and steamer (blue illuminated)
- Incl. measuring cup with egg pricker
- 230 V, 50 Hz, 380 W
- WxHxD approx. 235 x 270 x 160 mm



High-grade steel base incl. LCD display / timer with backlight





Stainless steel



Stainless steel

Ceramic coated

Contact grill
KG 2242 CB

- Contact grill for double-sided, fat-free grilling
 - Fat drainage channel and drip tray (tray removable for easy cleaning)
 - 2000 watts
 - Stainless steel housing
 - Continuously adjustable thermostat
 - Short cooking times
 - Non-stick grill plates with extra deep grooves for strong grill pattern and smooth fat drainage
 - Large, heat-insulated handle
 - 2 control lamps for power supply and heating
 - Temperature "ready" display
 - Large grill area: approx. 29.5 x 23.5 cm
 - Cord storage
 - Versatile, can be used for e.g. panini, steaks, fish or vegetables
- 220-240 V, 50/60 Hz, 2000 W
 - W x H x D approx. 335 x 145 x 330 mm

Contact grill
KG 2284 CB

- Contact grill for double-sided, fat-free grilling
 - Barbecue grill - 180° opening enables grilling on a large surface
 - Fat drainage channel and drip tray (tray removable for easy cleaning)
 - Stainless steel housing
 - Continuously adjustable thermostat
 - Short cooking times
 - Scratch-resistant, ceramic coated grill plates with extra deep grooves for strong grill pattern and optimal fat runoff
 - Large, heat-insulated handle
 - 2 control lamps for power supply and heating
 - Temperature "ready" display
 - Large grill areas: 2x approx. 29.5 x 23.5 cm
 - Cord storage
 - Versatile, can be used for e.g. panini, steaks, fish or vegetables
- 220-240 V, 50/60 Hz, 2000 W
 - W x H x D approx. 356 x 145 x 336 mm



Stainless steel housing



Scratch resistant ceramic coating



Stainless steel housing



Barbecue grill - 180° opening enables grilling on a large surface

Art. no. 622 421
EAN 4 004 470 224 214

PU 3



Art. no. 622 840
EAN 4 004 470 228 403

PU 3





Ceramic coated

Party pan
PP 2233 CB

- Party pan for cooking, roasting, steaming, defrosting and with keep warm function
- Quick heating and long keep warm function
- Removable supply line with continuously adjustable thermostat
- Anti-stick pan for easy cleaning
- Ø 32 cm, depth: 3.5 cm
- Heat-resistant glass lid with handle
- Heat-insulated carrying handles

- 220–240 V, 50/60 Hz, 1500 W
- WxHxD approx. 380 x 160 x 400 mm

Party pan
PP 2233 C CB

- Party pan for cooking, roasting, steaming, defrosting and with keep warm function
- Quick heating and long keep warm function
- Removable supply line with continuously adjustable thermostat
- Ceramic coated pan (scratch-proof and easy to clean)
- Ø 32 cm, depth: 3.5 cm
- Heat-resistant glass lid with handle
- Heat-insulated carrying handle

- 220–240 V, 50/60 Hz, 1500 W
- WxHxD approx. 380 x 160 x 400 mm



Scratch resistant ceramic coating

● Art. no. 622 331
EAN 4 004 470 223 316 PU 4



● Art. no. 622 332
EAN 4 004 470 223 323 PU 2





Party pan PP 1291 CB

- Party pan for cooking, roasting, steaming, defrosting and with keep warm function
- Quick heating and long keep warm function
- Removable supply line with continuously adjustable thermostat
- Non-stick coated pan (easy to clean)
- Ø 38 cm, depth: 4 cm
- Heat-resistant glass lid with handle
- Heat-insulated carrying handles

- 220–240 V, 50 Hz, 1400 W
- WxHxD approx. 450 x 140 x 400 mm

Party pan PP 2283 C CB

- Party pan for cooking, roasting, steaming, defrosting and with keep warm function
- Quick heating and long keep warm function
- Removable supply line with continuously adjustable thermostat
- Ceramic coated pan (scratch-proof and easy to clean)
- Ø 42 cm, depth: 9 cm
- Heat-resistant glass lid with handle
- Heat-insulated carrying handles

- 220–240 V, 50/60 Hz, 1500 W
- WxHxD approx. 430 x 145 x 490 mm

63



Scratch resistant ceramic coating

● Art. no. 612 910
 EAN 4 004 470 129 106 PU 2



● Art. no. 622 832
 EAN 4 004 470 228 328 PU 2





 **Stainless steel**

8 

8  **2in1**

64

Fondue set
FD 2248 CB

Raclette grill
RG 2247 CB

2 in 1 Raclette grill
RG 2279 CB

- Stainless steel fondue pot, rustproof (Ø 18.5 cm)
- Filling capacity up to max. 1.2 litres
- Fondue pot with encapsulated sandwich base for better heat distribution – also usable individually on different hobs (gas, electric, glass ceramic, halogen)
- Separate, stable hotplate made of stainless steel
- Continuously adjustable thermostat (illuminated)
- Thermal cut-out
- Thermal fuse
- Stainless steel splash protection with fork holder (removable)
- Accessories: 8 stainless steel fondue forks, color-coded
- 220–240 V, 50/60 Hz, 1200–1400 W
- W x H x D approx. 285 x 180 x 185 mm

- Cool touch housing
- For grilling and browning
- Removable grill plate
- 8 pans
- 8 wooden spatulas
- Continuously adjustable thermostat
- Control lamp
- Non-stick coating on the grill plates and pans (easy to clean)
- Grill area: approx. 40.5 x 30 cm
- Safe base through rubberised feet
- 220–240 V, 50/60 Hz, 1200–1400 W
- W x H x D ca. 430 x 130 x 340 mm

- Cool touch housing
- For grilling and browning
- Turning iron plate – Combination grill area for grilling fish (smooth surface) or meat (extra deep grooves for an intense grill pattern)
- Natural grill stone for a healthy, low-fat grilling
- Total grill area: ca. 46 x 23 cm (2x ca. 23 x 23 cm)
- 8 pans, 8 wooden spatula
- Continuously adjustable thermostat (blue illuminated)
- Non-stick coating on the grill plates and pans (easy to clean)
- 220–240 V, 50/60 Hz, 1200–1400 W
- W x H x D approx. 465 x 150 x 235 mm



Continuously adjustable thermostat (illuminated)



8 wooden spatulas



Natural grill stone for a healthy, low-fat grilling



Continuously adjustable thermostat (illuminated in blue)



Combination grill area for grilling fish or meat (turning iron plate)



● **Art. no. 622 481**
EAN 4 004 470 224 818 PU 4

● **Art. no. 622 471**
EAN 4 004 470 224 719 PU 3

● **Art. no. 622 791**
EAN 4 004 470 227 918 PU 2





Barbecue standing grill BQS 2244 CB

- Stand grill in an attractive design with low smoke emission and low smell
- Continuously adjustable thermostat with control lamp
- Chromed grill grid
- Removable grill and heating elements for easy cleaning
- Cool touch housing
- Metal drip tray
- Wind protection
- Additional tray
- Can be converted to a table grill
- Grill height: approx. 80 cm
- Grilling surface: 35.5 x 24.5 cm
- 230 V, 50 Hz, 2000 W
- W x H x D approx. 515 x 855 x 390 mm

Barbecue table grill BQ 2243 CB

- Table grill in an attractive design with low smoke emission and low smell
- Continuously adjustable thermostat with control lamp
- Chromed grill grid
- Removable grill and heating elements for easy cleaning
- Cool touch housing
- Metal drip tray
- Wind protection
- Grilling surface: 36 x 25 cm
- 230 V, 50 Hz, 2000 W
- W x H x D approx. 515 x 95 x 375 mm

Barbecue table grill BQ 1240 N CB

- Table grill in an attractive design without fire and smoke
- Cool touch housing
- On/off switch with indicator lamp
- Removable grill and heating elements for easy cleaning
- Metal drip tray
- Grilling surface: 35.5 x 24.5 cm
- 230 V, 50 Hz, 2000 W
- W x H x D approx. 480 x 100 x 360 mm



Grill rack and warming rack (enameled)



Convenient storage basket for different grilling utensils



Gas grill GG 2262 CB

- 2x heating zones for separate temperature control (2 Burner)
- Sturdy grill hood with integrated temperature display
- Control knobs for continuous temperature setting
- 48,5 x 37,5 cm grill area comprising of one enameled grill rack (dishwasher safe)
- 48,5 cm long warming rack (enameled)
- Removable grease collection tray for easy cleaning
- 2 x burners
- Housing and side trays made of powder-coated steel
- Two wheels for convenient movement
- Convenient storage basket for different grilling utensils
- Large storage room / Storage for gas bottle
- Including gas pressure reduction valve and gas tube for Germany and Austria

Specifications

- Burners: 2
- Main burner: 2x 2,75 kW / 5,5 kW
- Gas consumption: 400 gr/h
- Operating pressure: 50 mbar
- Ignition: Piezo ignition system
- Gas category: 13B/P(50)
- Gas type: Butane, propane, or their mixtures
- Target destinations: D, A, CH
- CE certification: Intertek institute, certification number: 0359BU1034
- W x H x D approx. 970 x 1000 x 550 mm



Integrated temperature display



Convection oven
HLO 2280 CB

Mini oven
MB 2245 CB

- Gentle cooking by circulating hot air, low-fat and vitamin-preserving
 - Many different uses for baking, roasting, grilling, steaming, braising, defrosting, heating, barbecuing (easy to use)
 - Halogen heating element for faster heating
 - Saves time and energy: requires up to 45 % less energy than a conventional oven
 - Ideal for small kitchens and mobile use
 - Continuously adjustable thermostat from 0 – 200 °C
 - 12 litre interior
 - Glass bowl: Ø 33 cm
 - Container made of safety glass – heat and scratch-resistant (dishwasher-safe)
 - 60 minute timer with alarm when cooking is completed
 - Control lamps for operation and temperature
 - Safety switch, practical safety handle
 - Heat-insulated carrying handles
 - Accessories: upper and lower grid, steamer insert, tongs, skewers, lid holder
- 220–240 V, 50/60 Hz, 1200–1400 W
 - WxHxD approx. 380 x 335 x 355 mm

- 8 litre capacity
 - Top and bottom heat
 - 15 minute timer
 - 2 quartz heating elements
 - Pull-out grill grid
 - Baking tray
 - Drawer for crumbs
 - Overheating protection
- 220–240 V, 50/60 Hz, 800 W
 - WxHxD approx. 365 x 220 x 250 mm



Lower/upper grid



Steamer insert

Art. no. 622 800
EAN 4 004 470 228 007

PU 1



Art. no. 622 451
EAN 4 004 470 224 511

PU 4





68

Multi pizza oven MPO 2246 CB

- Pizza oven ideal for grilling and crisping up
- Large grill, ideal for pizza (26 x 25 cm)
- Including baking tray (23.5 x 22 cm)
- Capacity: approx. 12 litre
- Top and bottom heat (combined operation possible)
- 4-step switch (top heat, bottom heat, top and bottom heat combined, off)
- 2 quartz heating elements
- 60 minute timer with end signal
- Stainless steel handle
- Crumb tray
- Overheating protection
- 220–240 V, 50/60 Hz, 1000 W
- WxHxD approx. 375 x 220 x 330 mm

Multi oven MBG 2249 CB

- 28 litre capacity
- Circulating air
- Top and bottom heat, combined operation
- Revolving spit
- 60 minute timer with end signal
- 5 level switch (top/bottom/top and bottom heat/revolving spit/off)
- Variable temperature control (100 °C – 230 °C)
- Control lamp
- Includes grill grid, baking tray, revolving spit
- Includes tongs for removing the grill grid and baking tray, tool for removing the revolving spit
- Large viewing window
- 220–240 V, 50/60 Hzz, 1500 W
- WxHxD approx. 520 x 335 x 420 mm



Incl. baking tray (23.5 x 22 cm)



Incl. revolving spit

● Art. no. 622 461
EAN 4 004 470 224 610 PU 4



● Art. no. 622 490
EAN 4 004 470 224 900 PU 1





NEW! Multi oven
MBG 2252 CB

- 28 litre capacity
- Circulating air
- Top and bottom heat, combined operation
- Revolving spit
- 60 minute timer with end signal
- 6 level switch
 - Top and bottom heat
 - Top and bottom heat + circulating air
 - Top heat + circulating air
 - Top heat + revolving spit
 - Top and bottom heat + revolving spit + circulating air
 - Off
- Variable temperature control (100°C–230°C)
- Control lamp
- Includes grill grid, baking tray, revolving spit
- Includes tongs for removing the grill grid and baking tray, tool for removing the revolving spit
- Large viewing window
- 220–240 V, 50/60 Hz, 1500 W
- W x H x D approx. 495 x 380 x 330 mm



Incl. revolving spit

Mini kitchen
KK 2250 CB

- 2 hotplates
 - 1x Ø 18.5 cm, 1500 watt
 - 1x Ø 15.5 cm, 1000 watt
- 2 different operating controls for the hotplates:
 - Small – rotary switch level 0–4
 - Large – rotary switch level 0, 850, 1100 and 1500 watt
- 28 litre capacity
- Combined operation (baking and cooking at the same time)
- Top and bottom heat (900/600 watt)
- Possible baking/grilling alternatives:
 - Top and bottom heat
 - Only bottom heat
 - Top heat
- Infinitely adjustable thermostat
- Control lamp
- Oven door with viewing window
- Including grill grating, baking sheet, and crumbs drawer, as well as hookable handle for pulling out the sheet/grating
- Power supply:
 - 600 watt oven (bottom heat), 900 watt oven (top heat)
 - 1000 watt hotplate (small), 1500 watt hotplate (large)
 - 3400 watt (total power consumption)
- 220–240 V, 50 Hz, 3400 W
- W x H x D approx. 515 x 360 x 390 mm



70

Microwave
MW 2235 CB

- 700 watt microwave
- 20 litre oven capacity
- 5 levels
- Rotating plate, Ø approx. 25.5 cm
- 35 minute timer with end signal
- Oven light
- Large viewing window

- 230 V, 50 Hz, 1050 W
- WxHxD approx. 440 x 255 x 340 mm

Microwave
MW 2288 CB

- 700 watt microwave
- 20 litre oven capacity
- 5 levels
- Rotating plate, Ø approx. 24.5 cm
- 30 minute timer with end signal
- Oven light
- Large viewing window

- 230 V, 50 Hz, 1200 W
- WxHxD approx. 455 x 265 x 340 mm

● Art. no. 622 350
EAN 4 004 470 531 329 PU 1
● Art. no. 622 351
EAN 4 004 470 223 514 PU 1



● Art. no. 622 880
EAN 4 004 470 228 809 PU 1
● Art. no. 622 889
EAN 4 004 470 228 892 PU 1
● Art. no. 622 881
EAN 4 004 470 228 816 PU 1





2in1

Microwave with grill

MWG 2237 CB

- 700 watt microwave
 - 1000 watt grill
 - 20 litre oven capacity
 - 5 microwave power levels
 - 3 levels in combined operation (grill/microwave)
 - 1 grill level
 - Rotating plate: Ø approx. 25.5 cm
 - Grilling grid: Ø approx. 21.0 cm
 - 35 minute timer with end signal
 - Oven light
 - Large viewing window
- 230 V, 50 Hz, 1050 W
 - WxHxD approx. 440 x 255 x 340 mm



2in1

Microwave with grill

MWG 2289 CB

- 700 watt microwave
 - 900 watt grill
 - 20 litre oven capacity
 - 5 microwave power levels
 - 3 levels in combined operation (grill/microwave)
 - 1 grill level
 - Rotating plate: Ø approx. 24.5 cm
 - Cooking grid: Ø approx. 21.0 cm
 - 30 minute timer with end signal
 - Oven light
 - Large viewing window
- 230 V, 50 Hz, 1200 W
 - WxHxD approx. 455 x 265 x 340 mm

● Art. no. 622 370
 EAN 4 004 470 531 336 PU 1
 ● Art. no. 622 371
 EAN 4 004 470 531 343 PU 1



● Art. no. 622 890
 EAN 4 004 470 228 908 PU 1
 ● Art. no. 622 899
 EAN 4 004 470 228 991 PU 1
 ● Art. no. 622 891
 EAN 4 004 470 228 915 PU 1



**3in1**

Convection

**3in1**

Convection

Stainless steel

Microwave with grill and convection MWG 2285 H CB

- Stainless steel front
 - 800 watt microwave power
 - 1350 watt grill
 - 1350 watt convection
 - Quick-start function
 - 20 litre capacity
 - 11 microwave power levels
 - 2 levels in combined operation (grill/microwave)
 - 4 levels in combined operation (convection/microwave)
 - 1 grill level
 - 10 temperature settings for convection
 - 9 automatic programs incl. defrost program
 - Rotating plate, Ø approx. 24.5 cm
 - Grilling grid, Ø approx. 21.0 cm
 - 95 minute timer with end signal
 - Quartz heating elements
 - Digital clock
 - Child lock
 - Oven light
- 230 V, 50 Hz, 1350 W
 - WxHxD approx. 455 x 262 x 375 mm

Microwave with grill and convection MWG 2281 H CB

- Stainless steel housing
 - Reflecting glass front
 - 800 watt microwave
 - 1200 watt grill
 - 1200 watt convection
 - 23 litre capacity
 - 4 microwave power levels
 - 3 levels in combined operation (microwave/grill)
 - 10 levels in combined operation (microwave/convection)
 - 1 grill level
 - 10 temperature settings for convection
 - 9 automatic programs
 - Defrost program
 - Rotating plate, Ø approx. 27.0 cm
 - Grilling grid, Ø approx. 22.0 cm
 - 95 minute timer with end signal
 - Quartz heating elements
 - Digital clock
 - Child lock
 - Oven light
- 230 V, 50 Hz, 1300 W
 - WxHxD approx. 485 x 295 x 405 mm

● Art. no. 622 851
EAN 4 004 470 228 519 PU 1



● Art. no. 622 811
EAN 4 004 470 228 113 PU 1





4in1

Stainless steel

Convection

1700 watt

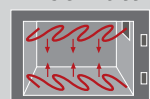

double grill

Stand-alone/
Under-cabinet mounting

Double-grill microwave MWG 2218 H CB

Combined microwave oven with grill MWG 2211 U CB

73

- Stainless steel housing
- Stainless steel interior
- Double grill for, for example, crispy pizza, baguettes, soufflés, etc. (1200 watt top heat, 500 watt lower heat)
- 900 watt microwave
- 1700 watt double grill
- 2300 watt convection
- Quartz top heating element
- 25 litre capacity
- 5 microwave power levels
- 10 temperature settings convection
- 10 automatic programs
- Defrost program
- Quick-start program
- Incl. pizza program and pizza stone, Ø approx. 30.0 cm
- Incl. enameled rotating plate, dishwasher-safe and scratchproof, Ø approx. 31.5 cm
- Grilling grid, Ø approx. 25.0 cm
- 95 minute timer with end signal
- Start delay
- Digital clock
- Child lock
- Oven light

- 230 V, 50 Hz, 1450 W
- W x H x D approx. 510 x 300 x 430 mm



Pizza function incl. pizza stone

- Stainless steel front
- 800 watt microwave
- 1000 watt grill
- 20 litre capacity
- 5 microwave power levels
- 2 levels in combined operation
- 1 grill level
- 8 automatic programs
- Defrost programs, selectable according to time and weight
- Quick-start program
- Rotating plate, Ø approx. 24.5 cm
- Grilling grid, Ø approx. 21.0 cm
- 95 minute timer with end signal
- Easy Tronic, digital clock, child lock
- Oven light
- Large viewing window
- Can be positioned as required or used as a built-under appliance (incl. installation material)
- 230 V, 50 Hz, 1250 W
- W x H x D approx. 460 x 285 x 370 mm



Built-under appliance

Art. no. 622 181
EAN 4 004 470 221 817

PU 1



Art. no. 622 111
EAN 4 004 470 221 114

PU 1





74

Built-in microwave with grill
MWG 2215 EB

Built-in microwave with grill and convection
MWG 2216 H EB

- Built-in microwave with frame
- Stainless steel front, stainless steel interior
- 800 watt microwave
- 1000 watt grill
- 5 microwave power levels
- 2 levels in combined operation (grill/microwave)
- 1 grill level
- 8 automatic programs
- Defrost programs, selectable according to time and weight
- 20 litre capacity
- Rotating plate, Ø approx. 24.5 cm, grilling grid, Ø approx. 21 cm
- 95 minute timer with end signal
- Start delay
- Child lock
- Oven light

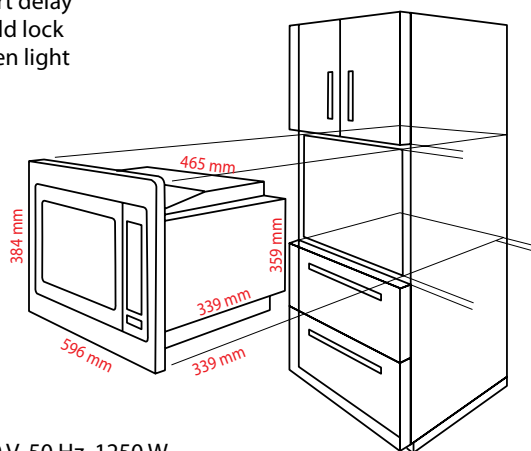

- 230 V, 50 Hz, 1250 W
- Appliance (W x H x D): 465 x 359 x 339 mm
- Appliance with frame (W x H x D): 596 x 384 x 339 mm
- Weight: approx. 14 kg

- Built-in microwave with frame
- Stainless steel front, stainless steel interior
- 900 watt microwave
- 1100 watt grill
- 2500 watt convection function
- 5 microwave power levels
- 2 levels in combined operation (grill/microwave)
- 2 levels in combined operation (convection/microwave)
- 1 grill level
- 10 temperature settings for convection (130 °C–220 °C)
- 10 automatic programs
- Defrost program, quick-start program
- 25 litre capacity
- Rotating plate, Ø approx. 31,5 cm, grilling grid, Ø approx. 27,5 cm
- 95 minute timer with end signal
- Start delay
- Child lock
- Oven light

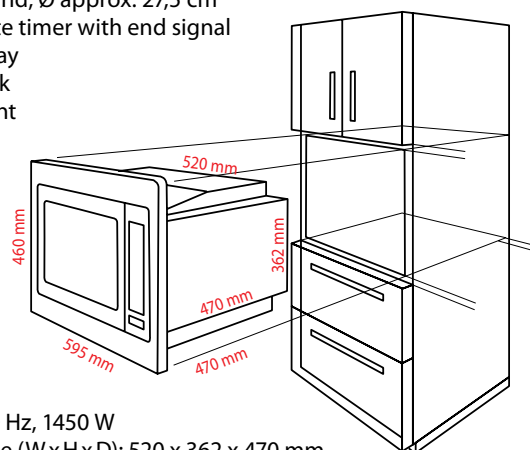

- 230 V, 50 Hz, 1450 W
- Appliance (W x H x D): 520 x 362 x 470 mm
- Appliance with frame (W x H x D): 595 x 460 x 470 mm
- Weight: approx. 21 kg

● Art. no. 622 151
EAN 4 004 470 221 510 PU 1



● Art. no. 622 161
EAN 4 004 470 221 619 PU 1



3in1



Built-in microwave with grill and convection MWG 2265 H EB

- Built-in microwave oven in frameless design
- Stainless steel front/interior
- Multi-function display (black/white)
- Control knob (illuminated)
- 900 watt microwave
- 1100 watt grill
- 2500 watt convection
- 5 microwave power levels
- 4 levels in combined operation (microwave/grill/convection)
- 1 grill level
- 10 temperature settings for convection (130°C–220°C)
- 10 automatic programs
- Defrost program, quick-start program
- 25 litre capacity
- Rotating plate, Ø approx. 31.5 cm,
- Grilling grid, Ø approx. 27.5 cm
- 95 minute timer with end signal
- Child lock
- Oven light

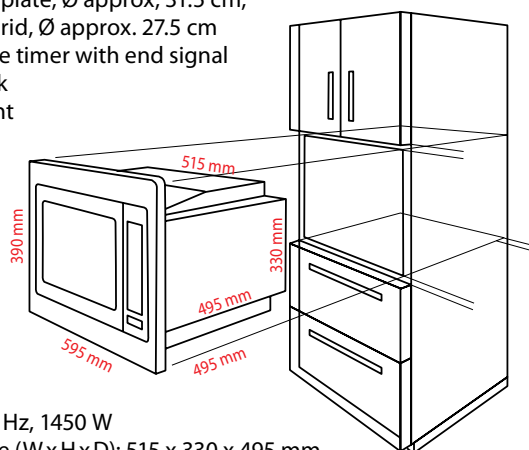

- 230 V, 50 Hz, 1450 W
- Appliance (WxHxD): 515 x 330 x 495 mm
- Appliance with frame (WxHxD): 595 x 390 x 495 mm
- Weight: approx. 21 kg



Single hotplate EKP 5027 CB

Double hotplate DKP 5028 CB

- Hotplate, Ø approx. 180 mm, 1500 watt
- Infinitely adjustable thermostat
- Control lamp
- Heat-resistant finish
- High stability
- 230 V, 50 Hz, 1500 W
- WxHxD approx. 360 x 70 x 285 mm

- 2 hotplates
 - 1 x Ø approx. 180 mm, 1500 watt
 - 1 x Ø approx. 150 mm, 1000 watt
- 2 continuously variable thermostats
- 2 control lamps
- Heat-resistant finish
- High stability
- 230 V, 50 Hz, 2500 W
- WxHxD approx. 570 x 70 x 285 mm

Art. no. 622 651
EAN 4 004 470 226 515 PU 1

Art. no. 650 270 (EKP 5027 CB)
EAN 4 004 470 502 701 PU 4
Art. no. 650 280 (DKP 5028 CB)
EAN 4 004 470 502 800 PU 3





Single induction hotplate EKI 5026 CB

- Induction hotplate with high-quality, eco-friendly glass-ceramic-surface
- Heating only takes seconds thanks to induction technology
- Scratch-resistant smooth cooking area, very easy to clean
- ECO-Save – 55 % time savings compared to conventional cooking plates, no preheating phase, energy saving
- Automatic pot detection – automatic switch-off in the case of non-induction pots
- 10 power levels and 10 temperature levels with LED indication (60° C – 240° C)
- Electronic sensor touch control panel with display for comfortable operation
- 3 LED control lamps
- 180 minute timer with automatic switch-off and end signal
- Countdown indication
- Automatic switch-off after 120 min. without operation
- Automatic switch-off after removal of the pot
- Child lock
- High stability through non-slip feet
- 220–240 V, 50/60 Hz, 2000 W
- W x H x D approx. 290 x 65 x 370 mm

Single induction hotplate EKI 5014 CB

- Induction hotplate with high-quality, eco-friendly Schott-Ceran® glass-ceramic surface
- Heating only takes seconds thanks to induction technology
- Scratch-resistant smooth cooking area, very easy to clean
- ECO-Save – 55 % time savings compared to conventional cooking plates, no preheating phase, energy-saving
- Automatic pot detection – automatic switch-off in the case of non-induction pots
- 10 power levels and 10 temperature levels
- Electronic control panel with display
- Easy to handle because of oversized buttons
- Power indication on LED display
- 180 minute timer with automatic switch-off and end signal
- Automatic switch-off after 120 min. without operation
- Automatic switch-off 15 sec. after removal of the pot
- 7 LED control lamps
- High stability through non-slip feet
- 230 V, 50 Hz, 2000 W
- W x H x D approx. 280 x 65 x 360 mm

Double induction hotplate DKI 5029 CB

- Induction double hotplate with high-quality, eco-friendly glass-ceramic-surface
- Heating only takes seconds thanks to induction technology
- Scratch-resistant smooth cooking area (very easy to clean)
- ECO-Save – 55% time savings compared to conventional cooking plates, no preheating phase, energy saving
- Automatic pot detection – automatic switch-off in the case of non-induction pots
- LED display
- Each hob with 16 function levels – 6 power levels and 10 temperature levels (60 °C–240 °C)
- Electronic Sensor Touch control panel with display for comfortable operation
- 2x 3 LED indicator lights
- 180 minute timer with automatic switch-off and end signal
- Countdown indication on the LED display
- Automatic switch-off after 120 min. without operation
- Automatic switch-off after removal of the pot
- High stability through non-slip feet
- 220–240 V, 50/60 Hz, 3500 W max.
- W x H x D approx. 600 x 75 x 355 mm

● Art. no. 650 261
EAN 4 004 470 502 619 PU 4



● Art. no. 650 141
EAN 4 004 470 501 414 PU 2



● Art. no. 650 291
EAN 4 004 470 502 919 PU 2



MC 701 CB



MC 702 CB



Textile cleaner

MC 701 CB / MC 702 CB



77

MC 701 CB

- Ideal for the easy removal of lint/pilling
- Handy size
- Metal lint grid
- Transparent lint container
- On/off switch
- Battery operation: 2x 1.5 V (UM3) (batteries not included)
- WxHxD approx. 36 x 76 x 76 mm

MC 702 CB

- Ideal for the easy removal of lint/pilling
- Handy size
- Metal lint grid
- Transparent lint container
- On/off switch
- Battery operation: 2x 1.5 V (UM3) (batteries not included)
- WxHxD approx. 60 x 85 x 170 mm

 Art. no. 607 010 (MC 701 CB)
 EAN 4 004 470 070 101 PU 20
 Art. no. 607 020 (MC 702 CB)
 EAN 4 004 470 070 200 PU 20





78

Steam iron DB 785 CB

- Special stainless steel sole plate
 - Steam jet function, spray device and vertical steam
 - Variable temperature control
 - Continuous steam regulation
 - Dry function (steam can be switched off)
 - Practical self-cleaning function
 - Transparent water container (approx. 135 ml)
 - Cable attached via 360° turnable joint
 - Indicator light
- 220–240 V, 50/60 Hz, 1700 W
 - WxHxD approx. 110 x 140 x 260 mm

Steam iron DB 765 CB

- Special stainless steel sole plate
 - Steam jet function, spray device and vertical steam
 - Variable temperature control
 - 3-level steam control
 - Dry function (steam can be switched off)
 - Practical self-cleaning function
 - Transparent water container (approx. 130 ml)
 - Cable attached via 360° turnable joint
 - Indicator light
- 230 V, 50 Hz, 2000 W
 - WxHxD approx. 115 x 155 x 275 mm

Steam iron DB 780 CB

- Special stainless steel sole plate
 - Steam jet function, spray device and vertical steam
 - Variable temperature control
 - Continuous steam regulation
 - Dry function (steam can be switched off)
 - Practical self-cleaning function
 - Transparent water container (approx. 200 ml)
 - Cable attached via 360° turnable joint
 - Indicator light
- 220–240 V, 50/60 Hz, 2200 W
 - WxHxD approx. 110 x 150 x 275 mm



Art. no. 607 850
EAN 4 004 470 078 503

PU 6



Art. no. 607 650
EAN 4 004 470 635 287

PU 6



Art. no. 607 800
EAN 4 004 470 078 008

PU 6





Ceramic

Steam iron
 DB 766 CB

- Special stainless steel sole plate
 - Steam jet function, spray device and vertical steam
 - Variable temperature control
 - Steam control
 - Dry function (steam can be switched off)
 - Anti-calc system
 - Anti-drip function
 - Practical self-cleaning function
 - Transparent water container (approx. 200 ml)
 - Open, rubberised handle
 - Cable attached via 360° turnable joint
 - Indicator light
- 220–240 V, 50/60 Hz, 2500 W
 ■ WxHxD approx. 124 x 144 x 280 mm

Steam iron
 DB 784 CB

- Special stainless steel sole plate
 - 7 functions:
 - Spray device
 - Steam jet function
 - Vertical steam
 - Dry function (steam can be switched off)
 - Self-cleaning function (switchable)
 - Anti-drip function
 - Anti-calc system
 - Variable temperature control
 - Continuous steam regulation
 - Transparent water container (approx. 360 ml)
 - Cable attached via 360° turnable joint
 - Indicator light
- 220–240 V, 50/60 Hz, 2500 W
 ■ WxHxD approx. 115 x 150 x 290 mm

Steam iron
 DB 781 CB

- Scratch-resistant ceramic sole plate with outstanding sliding behaviour
 - 5 functions:
 - Spray device
 - Steam jet function
 - Vertical steam
 - Dry function (steam can be switched off)
 - Self-cleaning function (switchable)
 - Variable temperature control
 - Continuous steam regulation
 - Transparent water container (approx. 250 ml)
 - Cable attached via 360° turnable joint
 - Indicator light
 - Measuring cup
- 220–240 V, 50/60 Hz, 1800–2200 W
 ■ WxHxD approx. 118 x 134 x 280mm



Easy-running, scratch-resistant ceramic sole plate

Art. no. 607 660
 EAN 4 004 470 635 294

PU 6



Art. no. 607 841
 EAN 4 004 470 078 411

PU 6



Art. no. 607 810
 EAN 4 004 470 078 107

PU 6





Ceramic

Steam iron
DB 782 CB

- Scratch-resistant ceramic sole plate with outstanding sliding behaviour
- 7 functions:
 - Spray device
 - Steam jet function
 - Vertical steam
 - Dry function (steam can be switched off)
 - Self-cleaning function (switchable)
 - Anti-drip function
 - Anti-calc filter system
- Variable temperature control
- 4-level steam control (0-1-2-3)
- Transparent water container (approx. 360 ml)
- Rubberised handle for non-slip handling
- Rubberised rest for excellent stability
- Cable attached via 360° turnable joint
- Indicator light
- 220–240 V, 50/60 Hz, 2400–2800 W
- WxHxD approx. 120 x 160 x 300 mm



Easy-running, scratch-resistant ceramic sole plate



Ceramic

Steam ironing unit
DBS 792 CB

- Scratch-resistant ceramic sole plate with outstanding sliding behaviour
- Steady-state heat resistance and optimal steam generation
- Even and consistent heat distribution through 20 spray nozzles
- With steam jet function (horizontal and vertical)
- Constant high steam output: max. 80 g/min.
- Removable water tank (2.3 litre capacity), in case of average operation sufficient for approx. 90 minutes
- Permanent refill function – refilling of the water tank during the operation possible
- Continuously adjustable temperature control
- 2 anti-calc cartridges
- Extra large rest plate to provide the iron with a stable rest
- Arrestable holding device
- Long connection cable
- Cable take-up on the base
- 230 V, 50/60 Hz, 2200 W max.
- WxHxD approx. 205 x 315 x 365 mm



Scratch resistant and smooth running ceramic sole plate



Removable water tank (2.3 litre capacity)



Replacement cartridge for DBS 792 CB

Art. no. 8 936 110
EAN 4 006 160 632 606

Art. no. 607 820
EAN 4 004 470 078 206 PU 6



Art. no. 607 921
EAN 4 004 470 079 210 PU 2
Art. no. 607 927
EAN 4 004 470 079 272 PU 2





Mini-washing machine

MWA 9485 CB

- Light mini-washing machine
- Obviates the need for tedious hand washing at home and when travelling
- Ideal for both small washes and for sensitive laundry items
- Washes quickly and effectively with a consistent result
- Low water, electricity and detergent consumption
- Ideally suited for camping, holidays and single households
- 15 minute timer
- Incl. drainage hose and water inlet
- Capacity: 13 litre max. / 1.5 kg
- 230 V, 50 Hz, 135 W
- WxHxD approx. 330 x 460 x 360 mm



15 minute timer



Incl. water inlet and drainage hose



Water level indicator



Detachable 1.2 litre capacity water tank



Vertical steam ironing for hanging clothes



Gentle and effective method for removing creases from fabrics

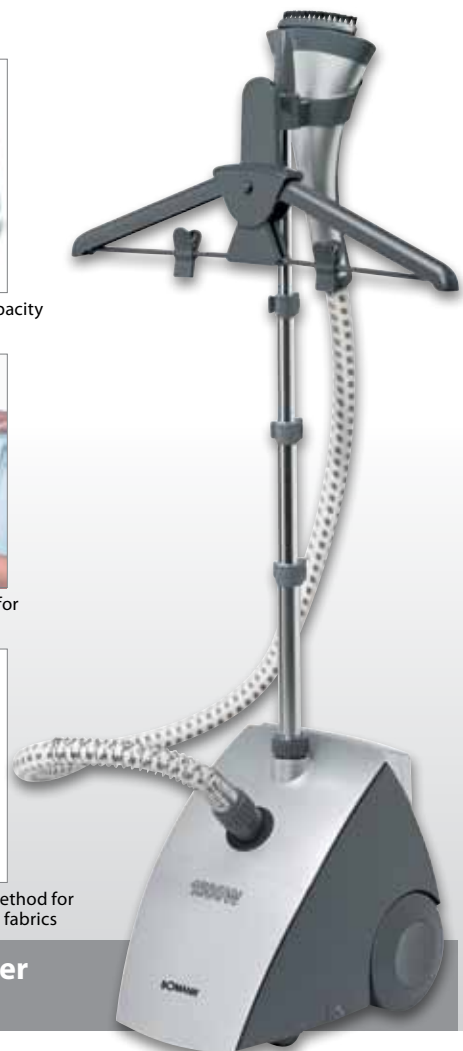

Fabric steamer

TDC 321 CB

- Steamer for steam ironing, removes wrinkles and lint
- Gentle and effective method for removing creases from fabrics
- The gentle steam effect extends the lifespan of your clothes
- Saves time over traditional ironing
- Also suitable for sensitive materials
- Vertical steam function
- Quick warm-up time through 1500 watt of power – ready to use in around 50 seconds
- Detachable 1.2 litre capacity water tank
- Use for up to 40 mins on a full tank
- Steplessly height-adjustable telescopic pole (to 1.35 m) for individual adjustment to body height and for easy storage
- Constant steam output: around 30 g/min.
- Vertical steam ironing for hanging clothes, curtains etc.
- Anti-drip system
- Easy to transport – through 2 large rollers and 2 360° casters
- Accessories: Trousers and clothes hanger, brush head, fabric brush attachment for removing wrinkles and bobbles
- On/off switch (illuminated)
- Overheating protection
- Fire protection fuse
- Cable length approx. 1.80 m
- 230 V, 50 Hz, 1500 W
- BxHxT ca. 340 x 1640 x 230 mm



Steam cleaner
DR 905 CB

- Steam cleaner, cleans, disinfects and degreases without limescale residues or streaks left behind from cleaning
- 3.5 bar steam pressure
- Approx. 300 ml water tank
- Long lead, approx. 5 m
- Overpressure protection
- Overheating protection
- Includes 9 accessories: 2x brush, nozzle, angle, fleece and windowcleaning attachments, hose, measuring beaker
- 220–240 V, 50/60 Hz, 1000 W
- WxHxD approx. 210 x 320 x 160 mm

Steam cleaner
DR 906 CB

- Steam cleaner, cleans, disinfects and degreases without limescale residues or streaks left behind from cleaning
- 3.5 bar steam pressure
- Approx. 600 ml water tank
- Aluminum boiler
- Control lamp (mains and standby)
- Safety tank lid with pressure relief valve
- Overheating protection
- On/off switch protected against water spray
- Practical carrying handle
- Smooth-running wheels
- Steam control on the handle
- Incl. 9 accessories: 2-part extendable insertable tube, floor brush, non-woven cloth, window wiper, jet nozzle attachments, round brush attachment, funnel, measuring beaker
- 230 V, 50/60 Hz, 1350 W
- WxHxD approx. 670 x 260 x 285 mm



2x round brush attachment



Jet nozzle attachment



Universal cleaning attachment



Angle attachment



Fleece



Measuring cup

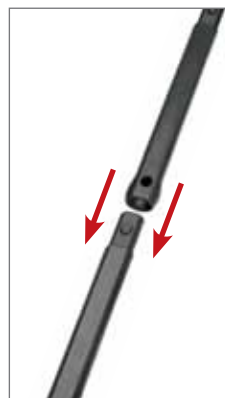

Extendable insertable tube



Floor brush



Round brush attachment



Window wiper



Angle attachment

Art. no. 609 051
EAN 4 004 470 090 512 PU 2



Art. no. 609 061
EAN 4 004 470 090 611 PU 1





Fleece attachment for thorough cleaning



Window-cleaning attachment, cleans without streaks and limescale residue



Accessories: 2x microfiber cloth, measuring beaker, window cleaner, nozzle, brush, carpet glider attachment



Space-saving storage by easy separation of the components

High-pressure cleaner HDR 9013 CB

- Mobile high-pressure cleaner with 2 large wheels for use in areas of gentle care like cars, motorcycles, bicycles, and also for powerful cleaning, such as sidewalks, garden furniture/tools, etc.
 - Approx. 90 bar
 - Delivery volume: 300 l max./h (5 l max./min.)
 - Area capacity: approx. 20 m²/h
 - Inlet temperature: 40°C max.
 - 1400 W max.
 - Integrated water filter for protection of the pump against entry of dirt
 - Large work reach by 5 m long connection cable and 5 m long high-pressure hose
 - Compact housing with low weight (5.7 kg)
 - Quick, clean and easy use of detergents with the practical detergent bottle (300 ml)
 - Adjustable high-pressure nozzle ■ High-pressure gun
 - On/off switch (splashproof)
 - Practical cable and hose winding on the unit for clean and space-saving storage
 - Additional accessories can be stored on the unit
 - Incl. carrying handle
- 230 V, 50 Hz, 1400 W
■ W x H x D approx. 255 x 480 x 245 mm



Incl. cleaning agent bottle (300 ml)



Incl. practical cable reel



Mobile use – gentle and powerful cleaning

Steam mop DR 904 CB



- Steam cleaner cleans, disinfects and removes grease at 100°C without grease marks and residues
 - Suitable for different surfaces: e.g. laminates, wooden floors, marble, rubber, slate, ceramics
 - Cleans fabric surfaces such as carpets, mats and cushions
 - Environmentally friendly and hygienic cleaning without the use of chemicals
 - Kills bacteria through high steam power
 - Maximum disinfection and intensive cleaning
 - Ready to use in around 30 seconds
 - Approx. 300 ml water tank
 - Use for up to 30 min. on a full tank
 - Up to 25 g steam/min.
 - Carpet glider attachment
 - Aluminium telescopic tube
 - Removable handle and nozzle for easy use by hand
 - Accessories: 2x microfiber cloth, measuring beaker, window cleaner, nozzle, brush
 - Long lead, approx. 5.0 m
 - Electric lead take-up
 - Fire protection fuse
- 220–240 V, 50/60 Hz, 1500 W
■ W x H x D approx. 260 x 1200 x 210 mm



Incl. spraying bottle

Window cleaner WC 908 CB

- Rechargeable battery-operated window cleaner set for daily use
 - Streak-free, time-saving, and hygienic cleaning for example of flat surfaces, windows, glass doors, mirrors, shower stalls, car windows, etc.
 - 2-in-1 cleaning/suction function
 - drip-free cleaning by 270 mm wide suction nozzle
 - thorough cleaning by 310 mm wide micro fleece attachment
 - High-power ni-mh battery for up to 40 min. cleaning time
 - Included spraying bottle and micro fleece attachment (machine-washable)
 - Easy handling because of low weight (600 g)
- Charging power supply: 230–240 V, 50/60 Hz
 - Battery: 3.6 V, 1500 mAh
 - WxHxD approx. 270 x 110 x 360 mm



Micro fleece cloth pad for cleaning (310 mm, removable)



Width suction nozzle for cleaning free of streak (270 mm)



Battery vacuum cleaner CB 967

- With 3 rechargeable Ni-Mh batteries
 - Nozzle for small gaps, brush nozzle
 - Permanent dust filter, washable
 - Charge control lamp (LED)
 - Charger mains adapter
 - Foot/wall mounting (installation materials not supplied)
- Charger mains adapter: 230 V, 50 Hz
 - Rechargeable battery: 3.6 V, 1400 mAh
 - WxHxD approx. 100 x 130 x 310 mm



Art. no. 609 081
EAN 4 004 470 090 819

PU 4



Art. no. 609 670
EAN 4 004 470 096 705

PU 6





Battery wet/dry vacuum cleaner AKS 960 CB

- Wet/dry vacuum cleaner
- Powerful battery vacuum cleaner with three rechargeable batteries
- Permanent dust filter, washable
- Charge control lamp (LED)
- Charger mains adapter
- Accessories: Recess nozzle, attachment for wet vacuuming, wall mounting
- Charger mains adapter: 230 V, 50 Hz
- Rechargeable battery: 3.6 V, 1400 mAh
- WxHxD approx. 110 x 130 x 380 mm

NEW! Battery vacuum cleaner AKS 713 CB

- Wet/dry vacuum cleaner
- Powerful battery vacuum cleaner with 10 rechargeable batteries
- Permanent dust filter (washable)
- Charge control lamp (LED)
- 12 V and battery operation possible
- Direct-Drive function: with fully discharged battery, the vacuum cleaner can be used immediately in 12 V operation
- Cable storage compartment
- Accessories: 2x crevice nozzle (1x 13 cm, 1x 26 cm), attachment for wet vacuuming, brush nozzle, 12 V adapter cable
- Charger mains adapter: 230 V, 50 Hz
- Rechargeable battery: 12 V / Battery (NiMh), 1400 mAh
- WxHxD approx. 125 x 130 x 400 mm

Hand vacuum cleaner CB 947

- Hand vacuum cleaner for vacuuming of: furniture, upholstery, frames, curtains, books, computers, cars, and much more
- Compact size: 24 x 12 x 15 cm
- Permanent dust filter
- Easy to clean
- 6 m cable
- Low weight
- Vertical storage (space saving)
- Accessories: flexible „vacuum snout“ with crevice nozzle, small and large brush, shoulder strap
- 230 V, 50 Hz, 700 W max.
- WxHxD approx. 110 x 185 x 360 mm

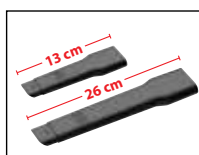

Extra-long crevice nozzles, for example, for use in the car



Attachment for wet vacuuming



360° brush nozzle



Art. no. 609 600
EAN 4 004 470 096 002

PU 6



Art. no. 607 139
EAN 4 004 470 071 399

PU 4



Art. no. 609 470
EAN 4 004 470 094 701

PU 6





B



A

Floor vacuum cleaner
BS 9011 CB

- 4-layer micro-filter system
- Metal suction tube
- Switchable floor brush
- Bag full display
- Practical carrying handle
- Automatic cable rewind
- Space-saving parking aid
- 2-fold accessories: brush/crevice nozzle

- 220–240 V, 50/60 Hz, 1000 W
- W x H x D approx. 245 x 229 x 316 mm

Spare bags:

SSB 101
Art. no. 282 047
EAN 4 004 470 820 478

NEW! Floor vacuum cleaner
BS 9019 CB

- 4-layer micro-filter system
- Stainless steel suction tube
- Switchable floor brush
- Bag full display
- Practical carrying handle
- Automatic cable rewind
- Space-saving parking aid
- 2-fold accessories: combined brush/crevice nozzle

- 220–240 V, 50/60 Hz, 700 W
- W x H x D approx. 256 x 205 x 310 mm

Spare bags:

SSB 98
Art. no. 282 193
EAN 4 006 160 821 932

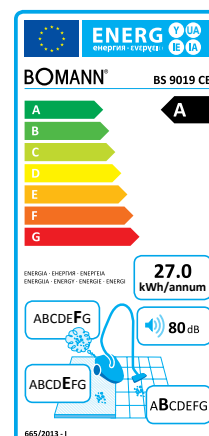
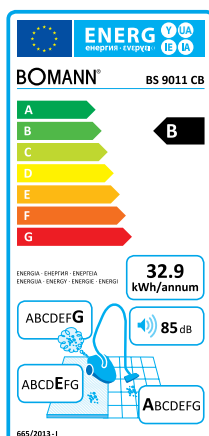

● Art. no. 690 110
EAN 4 004 470 901 108 PU 1



● Art. no. 690 195
EAN 4 004 470 901 955 PU 1





A



ELECTRONIC

Floor vacuum cleaner
BS 9014 CB

- Electronic power adjustment
- 4-layer micro-filter system
- Includes HEPA exhaust filter
- Stainless steel suction tube (approx. 84 cm length)
- Extra large operation range (approx. 8.30 m)
- Switchable floor brush
- Bag full display
- Rubberised rollers (ideal for sensitive floors)
- Practical carrying handle
- Automatic cable rewind
- Space-saving parking aid
- Integrated accessory tray
- 2-fold accessories: combined brush/crevice nozzle

- 220-240 V, 50/60 Hz, 800 W
- WxHxD approx. 255 x 205 x 370 mm

Spare bags:

SSB 98
Art. no. 282 193
EAN 4 006 160 821 932

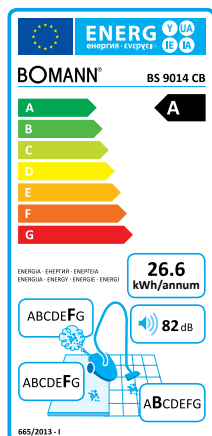

A



ELECTRONIC

Floor vacuum cleaner
BS 9010 CB

- Electronic power adjustment
- 4-layer micro-filter system
- Includes HEPA exhaust filter
- Stainless steel suction tube (approx. 85 cm length)
- Extra large operation range (approx. 8.30 m)
- Switchable floor brush
- Bag full display
- Rubberised rollers, ideal for sensitive floors
- Practical carrying handle
- Automatic cable rewind
- Integrated accessory tray
- Space-saving parking aid
- 2-fold accessories: combined brush/crevice nozzle

- 230 V, 50 Hz, 800 W
- WxHxD approx. 280 x 240 x 460 mm

Spare bags:

SSB 101
Art. no. 282 047
EAN 4 006 160 820 478

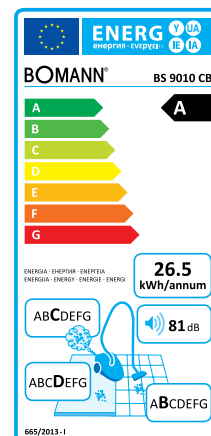



A **ELECTRONIC**



A **ELECTRONIC**

NEW! Floor vacuum cleaner
BS 9020 CB

- Electronic power adjustment
- 4-layer micro-filter system
- Includes HEPA exhaust filter
- Stainless steel suction tube (approx. 84 cm length)
- Extra large operation range (approx. 8.30 m)
- Switchable floor brush
- Incl. parquet brush
- Bag full display
- Rubberised rollers (ideal for sensitive floors)
- Practical carrying handle
- Automatic cable rewind
- Space-saving parking aid
- 3-fold accessories: crevice nozzle, upholstery nozzle, 360° brush attachment
- 220–240 V, 50/60 Hz, 700 W
- WxHxD approx. 291 x 246 x 457 mm

Spare bags:

SSB 101
Art. no. 282 047
EAN 4 006 160 820 478

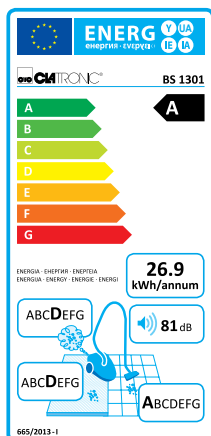

Floor vacuum cleaner
BS 9015 CB

- Electronic power adjustment
- 4-layer micro-filter system
- Includes HEPA exhaust filter
- Stainless steel suction tube (approx. 84 cm length)
- Extra large operation range (approx. 8.30 m)
- Switchable floor brush
- Bag full display
- Rubberised rollers (ideal for sensitive floors)
- Practical carrying handle
- Automatic cable rewind
- Space-saving parking aid
- 2-fold accessories: combined brush/crevice nozzle
- 220–240 V, 50/60 Hz, 700 W
- WxHxD approx. 280 x 240 x 320 mm

Spare bags:

SSB 101
Art. no. 282 047
EAN 4 006 160 820 478

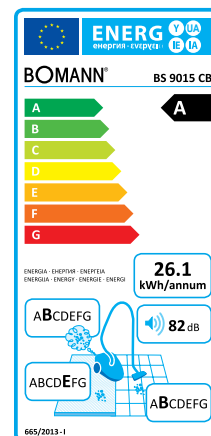

Art. no. 690 206
EAN 4 004 470 902 068 PU 1



Art. no. 690 151
EAN 4 004 470 901 511 PU 1





B



Floor vacuum cleaner
BS 9012 CB

- Eco-Cyclon
 - Bagless filter technology
 - 4-layer micro-filter system
 - Includes HEPA filter
 - Metal suction tube
 - Switchable floor brush
 - Rubberised rollers, ideal for sensitive floors
 - Practical carrying handle
 - Automatic cable rewind
 - Space-saving parking aid
 - 2-fold accessories: combined brush/crevice nozzle
- 220–240 V, 50/60 Hz, 1000 W
■ W x H x D approx. 235 x 290 x 365 mm

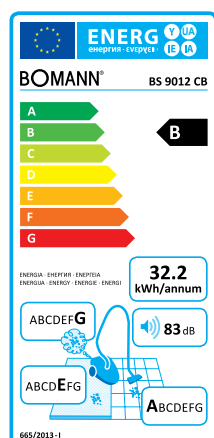

A



ELECTRONIC

Floor vacuum cleaner
BS 9018 CB

- Floor vacuum cleaner with energy-saving 700 Watt
 - Electronic power adjustment
 - Includes 2 HEPA filter
 - Height-adjustable telescopic tube
 - Adjustable floor brush
 - Bagless filter technology (no need to purchase dust bags)
 - Easy-to-empty, transparent dust-collecting container replaces conventional dust bag
 - Tank volume: 1.25 l
 - Motor protection filter (washable)
 - Rubberised rollers (ideal for parquet floors)
 - Automatic cable rewind
 - Space-saving parking aid
 - 3-fold accessories: combined brush/crevice nozzle, upholstery nozzle
- 220–240 V, 50/60 Hz, 700 W
■ W x H x D approx. 365 x 265 x 285 mm

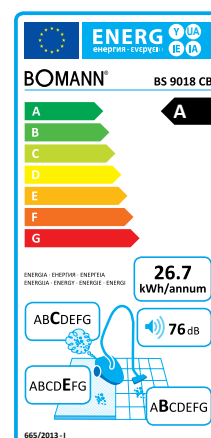



A   **ELECTRONIC**



2in1  **Stainless steel**

Floor vacuum cleaner
BS 9017 CB

- Eco-Cyclon twin spin floor vacuum cleaner with powerful max. 700 watt motor
 - Bagless Cyclon Twin Spin technique allows continual high suction power
 - Electronic power adjustment
 - 4-layer filter system
 - Includes HEPA filter
 - Stainless steel suction tube (approx. 84 cm length)
 - Extra large operation range (approx. 8.30 m)
 - Switchable floor brush
 - Rubberised rollers (ideal for sensitive floors)
 - Practical carrying handle
 - Automatic cable rewind
 - Space-saving parking aid
 - 3-fold accessories: combined brush/crevice nozzle, upholstery nozzle
- 230 V, 50 Hz, 700 W
 - W x H x D approx. 245 x 260 x 330 mm

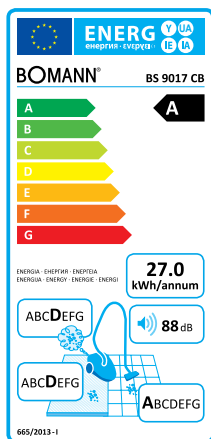

Wet and dry vacuum cleaner
BS 9000 CB

- Stainless steel housing
 - Large and comfortable wet and dry vacuum cleaner with powerful 1600 watt max.
 - Tank capacity: approx. 20 litres
 - Multi filter system
 - Incl. blower function, e.g. for easy removal of leaves
 - Draws coarse dirt as effectively as liquids
 - Optimal stability through 4 rollers
 - Deflection rollers (360°) allow smooth and flexible working
 - 2-part robust suction tube
 - Overflow protection by float valve
 - Practical holder on the vacuum cleaner for quick access and tidied accessory
 - 5 m cable allows large operation range
 - Accessories: brush/crevice nozzle, wet/dry brush, washable permanent filter
- 220–240 V, 50/60 Hz, 1600 W max.
 - W x H x D approx. 340 x 500 x 340 mm



Also ideal for the use on laminate, carpets etc.

Accessories: brush nozzle and crevice nozzle

- Art. no. 690 176
EAN 4 004 470 901 764 PU 1
- Art. no. 690 173
EAN 4 004 470 901 733 PU 1



- Art. no. 690 000
EAN 4 004 470 900 002 PU 1





Electronic bathroom scale PW 1417 CB

- Electronic glass bathroom scale with easy-to-read LCD display
- Weighing units in kg, lb, st (convertible)
- Measurement range of 2.5–150 kg (subdivided into 100 g steps)
- Low-maintenance standing surface
- Non-slip feet ensuring secure base
- Automatic switch-off (prolongs battery life)
- Battery operation: 1x CR 2032 (battery not included)
- W x H x D approx. 330 x 300 x 25 mm

Electronic bathroom scale PW 1418 CB

- Electronic glass bathroom scale with easy-to-read LCD display
- Weighing units in kg, lb, st (convertible)
- Measurement range of 2.5–150 kg (subdivided into 100 g steps)
- Low-maintenance standing surface
- Non-slip feet ensuring secure base
- Automatic switch-off (prolongs battery life)
- Battery operation: 1x CR 2032 (battery not included)
- W x H x D approx. 320 x 320 x 25 mm

Foot massager FM 8000 CB

- Intense whirlpool effect
- Massage burls for stimulating the foot reflex zones
- Additional massage roller, detachable, for selective foot reflex zone massage
- Heated footrest
- 4-level switches:
0 = off
1 = massage,
2 = warm/whirl
3 = warm/whirl/massage
- Can be used with and without water
- Splash guard, detachable
- Water level mark
- Spout
- Large rubber feet for slip-proof stand
- 230 V, 50 Hz, 90 W
- W x H x D approx. 300 x 120 x 380 mm





92

Nose and ear hair remover NE 8008 CB

- Conveniently and simply removes troublesome hairs in the nose and ears
- Includes light for improved personal grooming
- Removable fine-steel shearing head for cleaning
- On/off switch
- Incl. covering cap for the shearing head
- Battery operation: 1x 1.5 V (AA) (batteries not included)
- WxHxD approx. 30 x 130 x 35 mm

Hair and beard trimmer HSM 8006 CB

- Stainless steel precision shaving head for uniform haircut
- Stainless steel blade
- Stepless cutting length adjustment for efficient use of the comb attachments
- 4 comb attachments: 3, 6, 9, 12 mm
- Rubberized inlay for non-slip handling
- Accessories:
 - 4 comb attachments
 - Cleaning brush
 - Shearing head protection
 - Hanging loop
- 220-240 V, 50 Hz, 10 W max.
- WxHxD approx. 65 x 200 x 55 mm



Includes light for improved personal grooming

Promotional Packaging



● Art. no. 680 080
EAN 4 004 470 800 807 PU 12



● Art. no. 680 061
EAN 4 004 470 800 616 PU 12





2in1

Hair trimmer set HSM 8007 NE CB

Hair and beard trimmer:

- Stainless steel precision shaving head for uniform haircut
- Stainless steel blade
- Stepless cutting length adjustment for efficient use of the comb attachments
- 4 comb attachments: 3, 6, 9, 12 mm
- Soft touch inlay for non-slip handling
- Accessories: 4 comb attachments, cleaning brush, shearing head protection, comb, hanging loop
- 230–240 V, 50 Hz, 10 W max.
- W x H x D approx. 65 x 200 x 55 mm

Nose and ear hair remover:

- Gently and comfortably removes unsightly nose and ear hair
- Stainless steel shaving head, can be detached for cleaning
- Incl. cap for shaving head
- Battery operation: 1x 1.5 V (AA) (batteries not included)
- W x H x D approx. 28 x 130 x 30 mm



Hair crimper HC 8001 CB

- Hair crimper chromed
- Trouble-free styling due to the constant, long-lasting temperature
- Rapid heating
- Indicator light
- Soft touch housing
- Cable attached via 360° turnable joint
- On/off switch
- Incl. setting-down aid
- 230 V, 50 Hz, 25 W
- W x H x D approx. 280 x 35 x 70 mm

Hot air styler CB 856

- 2 power levels
- Roll key for accessories
- Ergonomically formed
- Cable with swivel cord 360°
- Safety cut-out
- 230 V, 50 Hz, 300 W
- W x H x D approx. 320 x 50 x 50 mm



Hot air styler
HAS 887 CB

- Powerful 550 watt motor
- 2 power levels + cold level "Cool Shot"
- Incl. 3 accessories: volume styler, round brush, regular brush
- Roll-out button for attachments
- Switchable voltage
- Overheating protection

- 110/230 V, 50/60 Hz, 550 W
- WxHxD approx. 305 x 45 x 45 mm

Travelling hair dryer
CB 818

- Compact sports hair dryer
- 2 power levels
- Removable shaping nozzle
- Switchable voltage
- Ring for hanging up
- Practical transparent bag

- 120/230 V, 50/60 Hz, 1200 W max.
- WxHxD approx. 130 x 195 x 70 mm



Incl. volume styler, round brush, regular brush

● Art. no. 608 879
● EAN 4 004 470 715 484 PU 12



● Art. no. 608 189
● EAN 4 004 470 081 893 PU 12





Hair dryer
HT 8002 CB

- Compact travelling hair dryer
- 2 temperature/power settings
- Removable shaped nozzle, rotatable through 360°
- Rubber profile on the casing avoid slipping
- Overheating protection
- Hanging loop

- 230 V, 50 Hz, 1200 W
- WxHxD approx. 111 x 210 x 75 mm



Hair dryer
HTD 8005 CB

- Compact travelling hair dryer
- Folding handle
- 2 temperature/power settings
- Removable shaped nozzle, rotatable through 360°
- Soft touch housing – rubberised surface to prevent slipping when putting down
- Includes volume diffuser and see-through bag for practical storage and when travelling
- Switchable voltage: 110/230 V
- Hanging loop

- 230 V, 50 Hz, 1300 W max.
- WxHxD approx. 170 x 235 x 75 mm



Professional hairstyler
HTD 889 CB

- Professional hairstyler with 2000 watt
- 3 temperature/power settings
- 2 speed settings
- Cool Shot
- Professional volume diffuser and shaping nozzle
- Air intake filter, removable
- Rubberised housing
- Avoid slipping
- Soft-touch grip
- Overheating protection
- Hanging loop

- 230 V, 50 Hz, 2000 W max.
- WxHxD approx. 270 x 270 x 90 mm



Art. no. 680 029
EAN 4 004 470 800 296

PU 12



Art. no. Nr. 680 056
EAN 4 004 470 800 562

PU 12



Art. no. 608 891
EAN 4 004 470 088 915

PU 6





Ø 23 cm

96

Professional hairstyler
HTD 899 CB

Table fan
VL 1137 CB

- Professional hairstyler with 2200 watt
- 3 temperature/power settings
- 2 speed settings
- Cool Shot
- Professional volume diffuser and shaping nozzle
- Air intake filter, removable
- Screw-in handle (space-saving)
- Soft touch housing – rubberised surface prevents slipping
- Includes travel bag with pull cord
- Safety thermal cut-out
- Hanging loop

- 230 V, 50 Hz, 2200 W
- WxHxD approx. 245 x 255 x 85 mm

- Oscillating (can be switched off)
- Adjustable angle of inclination
- Metal protection grid
- Safe base
- Ø approx. 23 cm
- 2 speed level
- 3-level switches (0-1-2)
- Practical carrying handle

- 220–240 V, 50/60 Hz, 30 W
- WxHxD approx. 275 x 375 x 220 mm



Incl. travel bag



Screw-in handle

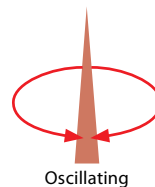

Oscillating

● **Art. no. 608 996**
EAN 4 004 470 089 967 PU 6



● **Art. no. 611 370**
EAN 4 004 470 611 373 PU 4



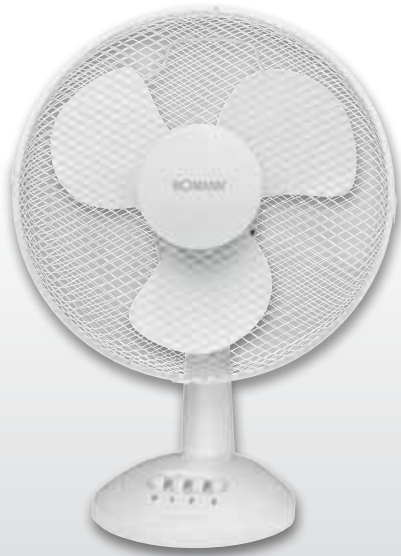

Ø 30 cm



Ø 40 cm



Table fan
VL 1138 CB

Standing fan
VL 1139 S CB

Fan heater
HL 1095 CB

- Oscillating (can be switched off)
- Adjustable angle of inclination
- Metal protection grid
- Safe base
- Ø approx. 30 cm
- 3 speed level
- 4-level switches (0-1-2-3)
- Practical carrying handle

- 220–240 V, 50/60 Hz, 40 W
- WxHxD approx. 340 x 480 x 245 mm

- Oscillating (can be switched off)
- Height-adjustable
- Adjustable angle of inclination
- Metal protection grid
- Safe base
- Ø approx. 40 cm
- 3 speed level
- 4-level switches (0-1-2-3)
- Practical carrying handle

- 220–240 V, 50/60 Hz, 45 W
- WxHxD approx. 430 x 1250 x 640 mm

- 2 heat settings (1000/2000 watt max.)
- Cold (ventilator)
- Infinitely adjustable thermostat
- Indicator light
- 2 different ways of setting up
- Safe base
- Sturdy carrying handle
- Overheating protection

- 220–240 V, 50 Hz, 1800–2000 W
- WxHxD approx. 248 x 120 x 250 mm

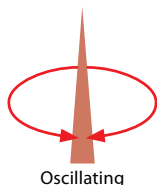

Oscillating

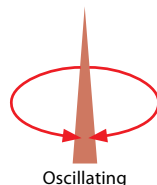

Oscillating



2 different ways of setting up

● **Art. no. 611 380**
EAN 4 004 470 611 380 PU 4



● **Art. no. 611 390**
EAN 4 004 470 611 397 PU 3



● **Art. no. 610 950**
EAN 4 004 470 109 504 PU 4





98

Fan heater HL 1096 CB

- 2 heat settings (1000/2000 watt)
- Cold (ventilator)
- Infinitely adjustable thermostat
- Indicator light
- Safe base
- Sturdy carrying handle
- Overheating protection
- 220–240 V, 50 Hz, 2000 W
- WxHxD approx. 230 x 138 x 262 mm

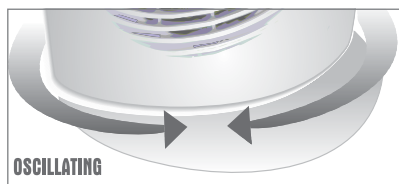

NEW! Ceramic fan heater HL 1097 CB

- PTC ceramic heater element for healthy, safe, quiet and efficient heating
- Low dust accumulation
- Quick and effective heating
- Long service life
- Robust and durable
- 7 level switches
- 2 heat settings (750/1500 W)
- Oscillating (can be deactivated)
- Cold setting (fan blower)
- Steplessly adjustable thermostat
- Safety switch for fire protection
- Stable stand
- Robust carry handle (foldable)
- Overheat protection
- 220–240 V, 50 Hz, 1500 W
- WxHxD approx. 191 x 267 x 141 mm



Air dehumidifier LE 1150 CB

- Dehumidification power: 12 L/24 h
- Air circulation in m³:
 - Level 1: approx. 100 m³/h
 - Level 2: approx. 140 m³/h
- LED display (blue illuminated)
- Humidity indicator
- Electronic humidity control
- The desired humidity can be set from 40 to 80 %
- 24 hour timer
- 1 L water tank (detachable)
- Fold-out carrying handle
- Convenient rollers
- Automatic stop + warning signal with full tank
- Low noise
- Removable air filter (easy to clean)
- Hose connector for permanent water drain
- Incl. water hose (1 m)
- On/off switch
- Coolant: R134A
- Ideal for rooms up to 15 m²
- 220–240 V, 50 Hz, 220 W
- WxHxD approx. 280 x 520 x 185 mm



Art. no. 610 960
EAN 4 004 470 109 603 PU 4



Art. no. 610 971
EAN 4 004 470 109 719 PU 4



Art. no. 611 509
EAN 4 004 470 115 093 PU 2





A+

A++

Cool box
KB 9486 CB

Cool box
KB 9487 CB

- Suitable for cooling and warming
 - Perfect for camping, travel and shopping
 - Capacity (gross capacity): ca. 25 litre max.
 - Even cooling by integrated fan
 - Powerful, maintenance-free Peltier cooling/heating system
 - Energy saving function
 - Double walled plastic casing with high quality isolation
 - Special sealing rubber in the lid reduces condensation
 - Control lights for cooling and warming function
 - Foldable handle
 - Removable lid
 - Accessory: 12 V connecting cable (detachable), 230 V connecting cable (detachable)
- Power supply:
- Mains adapter connection: DC 12 V, 40/48 W
 - Mains adapter connection: AC 220–240 V, ~ 50/60 Hz, 52/58 W, 11 W (ECO mode)
- WxHxD approx. 405 x 435 x 300 mm

- Suitable for cooling and warming
 - Perfect for camping, travel and shopping
 - Capacity (gross capacity): ca. 30 litre max.
 - Even cooling by integrated fan
 - Powerful, maintenance-free Peltier cooling/heating system
 - Energie saving function
 - Double walled plastic casing with high quality isolation
 - Special sealing rubber in the lid reduces condensation
 - Control lights for cooling and warming function
 - Foldable handle
 - Removable lid
 - Cable storage compartment
 - Accessory: 12 V connecting cable, 230 V connecting cable
- Power supply:
- Mains adapter connection: DC 12 V, 40/48 W
 - Mains adapter connection: AC 220–240 V, ~ 50/60 Hz, 52/58 W, 8 W (ECO mode)
- WxHxD approx. 405 x 435 x 300 mm



For all standard 0.75 / 1.0 / 1.5-litre bottles

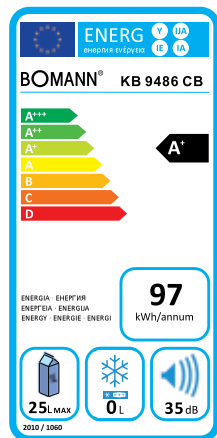

For all standard 0.75 / 1.0 / 1.5-litre bottles

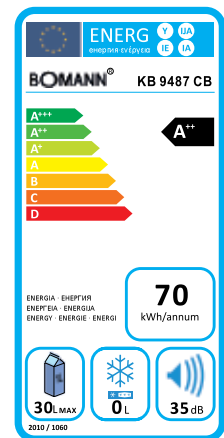

Art. no. 694 861
EAN 4 004 470 948 615

PU 1



Art. no. 694 871
EAN 4 004 470 948 714

PU 1



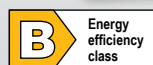
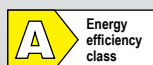

Wine cooler KSW 344

- Bottle capacity: 16 at 0.75 litres
- Net capacity: 46 litres
- Control panel with LED-display (blue illuminated)
- Electronical temperature setting and -control
- Eco-friendly, without coolant

General

- Wine storage cabinet
- Thermoelectric cooling
- Climate class N (+16 °C to +32 °C)
- Low-noise 43 dBA, without vibration
- Without compressor

Features

- Digital temperature settings and display (blue illuminated)
- Temperature settings from +11 °C to +18 °C, max. 14 °C below ambient temperature
- LED interior light (separate switchable)
- 3 removable shelves made of chrome (W 35.0 x D 26.5 cm)
- Double pane door with recessed handle
- Housing black color, door frame in silver color
- Adjustable feet
- 230 V~, 70 W
- W x H x D approx. 420 x 520 x 480 mm

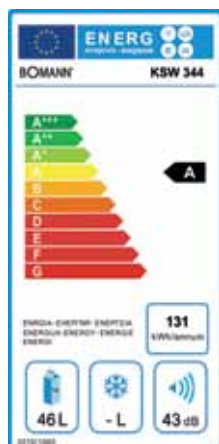

Wine cooler KSW 345

- Bottle capacity: 18 at 0.75 litres
- Net capacity: 54 litres
- Control panel with LED-display (blue illuminated)
- Electronical temperature setting and -control
- Eco-friendly, without coolant

General

- Wine storage cabinet
- Thermoelectric cooling
- Climate class N (+16 °C to +32 °C)
- Low-noise 39 dBA, without vibration
- Without compressor

Features

- Digital temperature settings and display (blue illuminated)
- Temperature settings from +11 °C to +18 °C, max. 14 °C below ambient temperature
- LED interior light (separate switchable)
- 5 removable shelves made of chrome (W 27.5 x D 26.5 cm)
- Double pane door with recessed handle
- Housing black color, door frame in silver color
- Adjustable feet
- 230 V~, Connection power: 70 W
- W x H x D approx. 345 x 636 x 515 mm

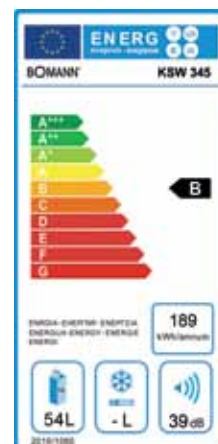

● Art. no. 734 400
EAN 4 004 470 734 409 PU 1



● Art. no. 734 500
EAN 4 004 470 734 508 PU 1





Replacement bottle/ Replacemant jars

Replacement bottle for Smoothie maker SM 386 CB

Art. no. 264 559
EAN 4006 160 645 590 PU 6

Replacement jars for Yoghurt-Maker JM 1025 CB

Art. no. 251 125
EAN 4006 160 511 253 PU 4



Replacement cartridges

Replacement cartridges for DBS 778 CB, DBS 783 CB

Art. no. 8 934 610
EAN 4006 160 632 583 PU 3

Replacement cartridges for DBS 792 CB

Art. no. 8 936 110
EAN 4006 160 632 606 PU 3



Spare rolls for bag sealer

Spare rolls for FS3261

Art. no.: 282 020
EAN 4 006 160 820 201 PU 10



Dust bags

You will find other accessory articles under www.bomann.de

Vacuum Cleaners	Article-No.	EAN No.	Bomann Type	Swirl Type
BS 902 CB	282193	4004470 821932	SSB 98	Y 98
BS 911 CB	282047	4006160820478	SSB 101	Y 05
CB 925	309250	4004470 309256	B 45	Y 101
CB 917/918/929	282049	4006160 820492	SSB 104	Y 104
CB 940	282047	4006160 820478	SSB 101	Y 93
CB 941	309410	4004470 309416	B 49	Y 101
CB 942	282047	4006160 820478	SSB 101	Y 101
CB 946	282193	4006160 821932	B 52/SSB 98	Y 98
CB 948	282047	4006160 820478	SSB 101	Y 101
CB 949	282047	4006160 820478	SSB 101	Y 05
CB 950	282207	4006160 822076	SSB 30	Y 30
CB 952/953	282049	4006160 820492	SSB 104	Y 104
CB 957	282047	4006160 820478	SSB 101	Y 101
BS 961 CB	282047	4006160 820478	SSB 101	Y 101
CB 962	282049	4006160 820492	SSB 104	Y 104
CB 965	282047	4006160 820478	SSB 101	Y 93
CB 966	282047	4006160 820478	SSB 101	Y 05
BS 968 CB	282193	4006160 821932	SSB 98	Y 298
BS 973 CB / BS 986 CB	282193	4006160 821932	SSB 98	Y 298
BS 974 CB	282193	4006160 821932	SSB 98	Y 298
BS 976 CB	–	–	–	Y 293
BS 980 CB	282047	4006160 820478	SSB 101	Y 50
BS 981 CB	–	–	–	R 23
BSS 982 CB	8126102	–	BSS 1261	R 23
BS 985 CB / BS 988 CB	282047	4006160 820478	SSB 101	Y 93
BS 987 CB	282047	4006160 820478	SSB 101	Y 101
BS 989 CB / BS 9014 CB / BS 9019 CB	282193	4006160 821932	SSB 98	Y 98
CB 991	282047	4006160 820478	SSB 101	Y 05
CB 992	282193	4006160 821932	SSB 98	Y 98
CB 993	282207	4006160 822076	SSB 30	Y 230
BS 9010 CB / BS 9011 CB / BS 9015 CB / BS 9020 CB	282047	4006160 820478	SSB 101	–



Filter-sets

Vacuum Cleaners	Article-No.	EAN No.	Bomann Type
BS 912 CB	8912800	–	Filterset BS 1280
CB 954	282840	4006160 828405	Filterset BS 1228
CB 955	612290	4006160 122909	Filterset BS 1229
CB 956	282862	4006160 828627	Filterset BS 1236
BS 958 CB	282918	4006160 829181	Filterset BS 1273
CB 964	282886	4006160 828863	Filterset BS 1240
BS 970 CB	271576	4006160 715767	Filterset BS 1247
BS 971 CB	282906	4006160 829068	Filterset BS 1248
BS 972 CB	282907	4006160 829075	Filterset BS 1249
BS 975 CB	282914	4006160 829143	Filterset BS 1253
BS 979 CB	271596	4006160 715965	Filterset BS 1256
BS 983 CB	282907	4006160 829075	Filterset BS 1249
BS 984 CB	271575	4006160 715750	Filterset BS 1255
CB 997	282850	4006160 828504	Filterset BS 1234



HEPA-filter

Vacuum Cleaners	Article-No.	EAN No.	Bomann Type
CB 939	209390	4004170 093905	–
CB 950	282203	4006160 822038	Filter BS 1224

TECHNICAL DATA FOR VACUUM CLEANERS
Commission Delegated Regulation (EU) No. 665/2013

Bomann										
Model	BS 9010 CB	BS 9011 CB	BS 9012 CB	BS 9014 CB	BS 9015 CB	BS 9017 CB	BS 9018 CB	BS 9019 CB	BS 9020 CB	
Energy efficiency class ¹⁾	A	B	B	A	A	A	A	A	A	
Energy consumption										
Annual energy consumption ²⁾	kWh	26.5	32.9	32.2	26.6	26.1	27.0	26.7	27.0	26.9
Cleaning performance class										
Carpet cleaning performance class	D	E	E	F	E	D	E	E	D	
Hard floor cleaning performance class	B	A	A	B	B	A	B	B	A	
Dust re-emission class										
Dust re-emission class	C	G	G	F	B	D	C	F	D	
Sound power level	dB(A) re 1pW	81	85	83	82	82	88	76	80	81
Rated input power	W	800	1.000	1.000	800	700	700	700	700	700

¹⁾ A (highest efficiency) to G (lowest efficiency).

²⁾ Indicative annual energy consumption (kWh per year), based on 50 cleaning tasks. Actual annual energy consumption will depend on how the appliance is used.

The device meets the European standards and directives in the current version at delivery:

- Low Voltage Directive (LVD) 2006/95/EC
- Electromagnetic Compatibility (EMC) Legislation Directive 2004/108/EC
- Ecodesign requirements for vacuum cleaners COMMISSION REGULATION (EU) No 666/2013

TECHNICAL DATA FOR HOUSEHOLD REFRIGERATORS
Commission Delegated Regulation (EU) No. 1060/2010

Bomann						
Model	KB 9486 CB	KB 9487 CB	KSW 344	KSW 345		
Category ¹⁾	10	10	2	2		
Energy efficiency class ²⁾ A+++ (highest efficiency) to G (lowest efficiency)	A+	A++	A	B		
Consumption data						
Annual energy consumption ³⁾	kWh	97	70	131	189	
Net capacity cooling total	l	25	30	-	-	
- thereof cold storage compartment	l	-	-	-	-	
- thereof wine storage compartment	l	-	-	-	-	
- thereof cellar compartment	l	-	-	-	-	
- thereof storage compartment for fresh-food	l	-	-	-	-	
Net capacity freezing	l	-	-	-	-	
Star rating ⁴⁾		-	-	-	-	
Design temperature of other compartments	°C	-	-			
Coldest storage temperature of wine storage compartment	°C	-	-	+11	+11	
Frost-free		-	-	-	-	
Temperature rise time	h	-	-	-	-	
Freezing capacity	kg/ 24 h	-	-	-	-	
Climate class ⁵⁾		SN/N	SN/N	N	N	
Noise level	dB(A) re 1pW	35	35	43	39	
Built-in / integrable		-/-	-/-	-/-	-/-	
Wine storage appliance		-/-	-/-	•	•	

¹⁾ Category: 1 = Refrigerator with one or more fresh-food storage compartments, 2 = Refrigerator-cellar, Cellar and Wine storage appliances, 3 = Refrigerator-chiller and Refrigerator with a 0-star compartment, 4 = Refrigerator with a one-star compartment, 5 = Refrigerator with a two-star compartment, 6 = Refrigerator with a three-star compartment, 7 = Refrigerator-freezer, 8 = Upright freezer, 9 = Chest freezer, 10 = Multi-use and other refrigerating appliances.

²⁾ A+++ (highest efficiency) to G (lowest efficiency).

³⁾ Annual energy consumption „XYZ“ kWh per year based on standard test results for 24 h. Actual energy consumption will depend on how the appliance is used and where is located.

⁴⁾ * = compartment: a frozen-food storage compartment in which the temperature is not warmer than -6°C.

*** = compartment: a frozen-food storage compartment in which the temperature is not warmer than -18°C.

(*)*** = food freezer compartment in which the temperature is not warmer than -18°C and a minimum freezing capacity in 24 h.

⁵⁾ Climate class SN: ambient temperature of +10°C up to +32°C.

Climate class N: ambient temperature of +16°C up to +32°C.

Climate class ST: ambient temperature of +16°C up to +38°C.

Climate class T: ambient temperature of +16°C up to +43°C.





BOMANN®

C. Bomann GmbH
Heinrich-Horten-Straße 17
47906 Kempen
Germany

Telephone: +49 2152 8998-0
Telefax: +49 2152 8998-911

mail@bomann.de
www.bomann.de